

L I N H A S E X C L U S I V A S

SP
20

Desde 1986
aluminorte
alumínio e acessórios

EM COMPARAÇÃO ÀS LINHAS DE MERCADO CONVENCIONAIS,
A SP 20 SE DESTACA POR SER UMA LINHA ECONÔMICA QUE NÃO ABRE MÃO DA
QUALIDADE E SEGURANÇA COMPROVADA EM TESTES DE LABORATÓRIO



SISTEMA TESTADO E APROVADO



FACILIDADE NA FABRICAÇÃO



MAIOR PRODUTIVIDADE



LINHA HOMOLOGADA
de acordo com as normas vigentes

SOLICITE SEU
ORÇAMENTO

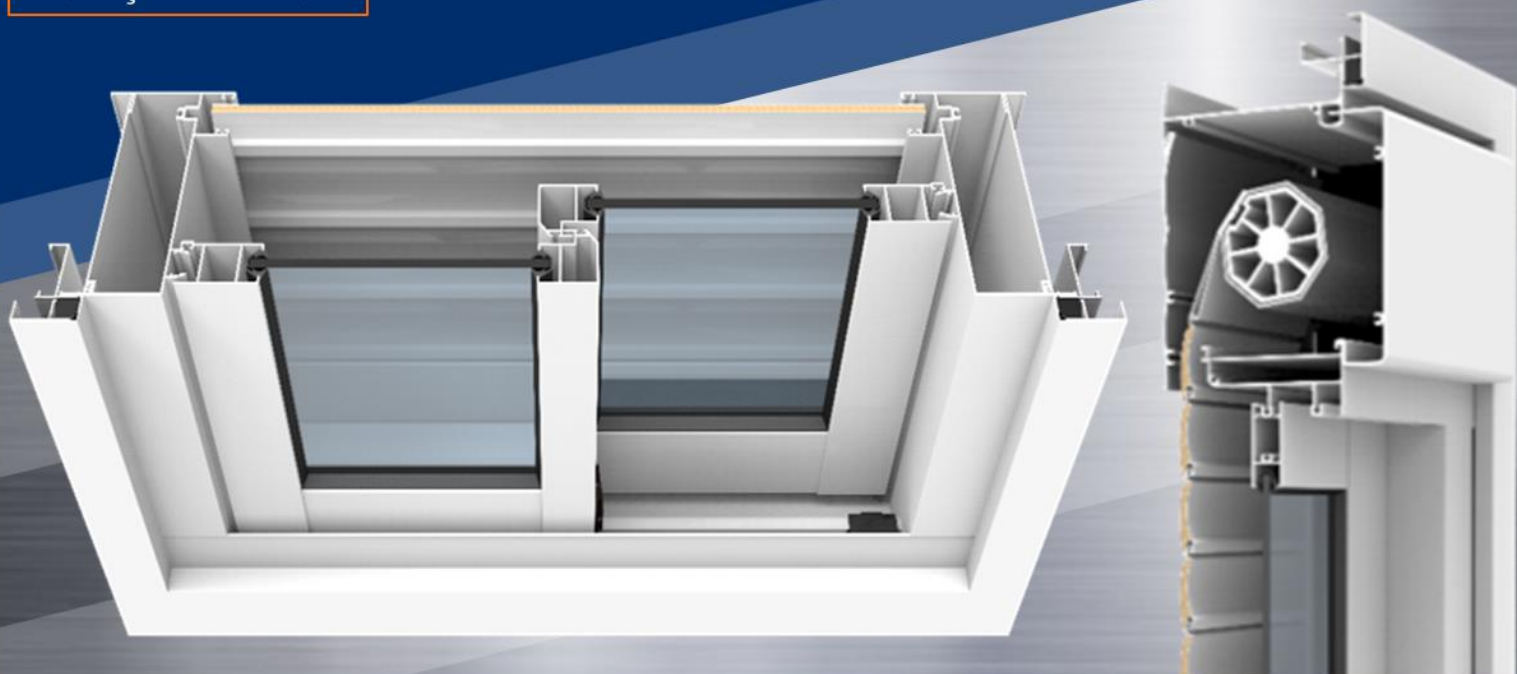

ÍNDICE DE PERFIS _____	01
PERFIS _____	03
TIPOLOGIAS _____	37
DIAGRAMA DE DIMENSÕES _____	40
COMPONENTES _____	52
PROJETOS ORIENTATIVOS _____	56
NORMAS _____	74
TESTES _____	76



CÓDIGO	PESO	PÁG	CÓDIGO	PESO	PÁG
20SP – 018	0,143 Kg/m	03	20SP – F56	0,669 Kg/m	18
20SP – 202	0,080 Kg/m	03	20SP – F57	0,584 Kg/m	17
20SP – F01	0,422 Kg/m	13	20SP – F58	0,946 Kg/m	19
20SP – F02	0,422 Kg/m	13	20SP – F59	0,378 Kg/m	17
20SP – F03	0,399 Kg/m	13	20SP – F85	0,350 Kg/m	15
20SP – F04	0,464 Kg/m	13	20SP – F90	0,347 Kg/m	15
20SP – F05	0,373 Kg/m	16	20SP - F91	0,346 Kg/m	15
20SP – F06	0,602 Kg/m	14	20SP – F92	0,439 Kg/m	15
20SP – F07	0,580 Kg/m	14	20SP – M01	0,674 Kg/m	04
20SP – F08	0,972 Kg/m	13	20SP – M02	0,596 Kg/m	04
20SP – F09	0,520 Kg/m	16	20SP – M03	0,382 Kg/m	05
20SP – F10	0,350 Kg/m	16	20SP – M04	0,888 Kg/m	07
20SP – F11	0,808 Kg/m	14	20SP – M05	0,786 Kg/m	07
20SP – F12	0,826 Kg/m	14	20SP – M06	0,470 Kg/m	08
20SP – F20	0,135 Kg/m	23	20SP – M07	0,555 Kg/m	08
20SP – F34	0,161 Kg/m	22	20SP – M19	0,138 Kg/m	05
20SP – F35	0,097 Kg/m	20	20SP – M21	0,417 Kg/m	22
20SP – F42	0,420 Kg/m	17	20SP – M22	0,337 Kg/m	22
20SP – F43	0,401 Kg/m	17	20SP – M23	0,173 Kg/m	22
20SP – F44	0,918 Kg/m	19	20SP – M24	0,341 Kg/m	21
20SP – F45	0,790 Kg/m	19	20SP – M25	0,552 Kg/m	21
20SP – F46	0,810 Kg/m	19	20SP – M28	0,162 Kg/m	22
20SP - F48	0,200 Kg/m	17	20SP – M29	0,273 Kg/m	21
20SP – F49	0,314 Kg/m	20	20SP - M30	0,304 Kg/m	21
20SP – F50	0,080 Kg/m	17	20SP – M31	0,135 Kg/m	22
20SP – F51	0,484 Kg/m	20	20SP – M35	0,568 Kg/m	12
20SP – F52	0,350 Kg/m	20	20SP – M36	0,651 Kg/m	12
20SP – F54	0,561 Kg/m	18	20SP – M37	0,964 Kg/m	11
20SP – F55	0,591 Kg/m	18	20SP – M38	0,921 Kg/m	11

ÍNDICE DE PERFIS

CÓDIGO	PESO	PÁG	CÓDIGO	PESO	PÁG
20SP – M39	0,999 Kg/m	05	MP – 347	0,200 Kg/m	03
20SP – M40	0,493 Kg/m	04	SPA – 101	0,290 Kg/m	23
20SP – M41	1,081 Kg/m	05	SPA - F105	0,367 Kg/m	26
20SP – M43	0,352 Kg/m	04	SPA - F109	0,909 Kg/m	26
20SP - M59S	0,660 Kg/m	05	SPA - M108	0,658 Kg/m	24
20SP – M65	0,725 Kg/m	27	SPA - M110	0,135 Kg/m	24
20SP – M66	0,730 Kg/m	09	SPA - M111	0,852 Kg/m	24
20SP – M67	0,674 Kg/m	09	SPA - M113	0,485 Kg/m	25
20SP - M68	0,442 Kg/m	09	SPA - M114	0,574 Kg/m	25
20SP – M69	0,326 Kg/m	10	SPI - I04	0,687 Kg/m	36
20SP – M70	0,469 Kg/m	12	SPI - M11	0,559 Kg/m	29
20SP – M71	0,200 Kg/m	08	SPI - M12	1,267 Kg/m	35
20SP – M74	0,436 Kg/m	12	SPI - M13	1,267 Kg/m	35
20SP – M75	0,247 Kg/m	11	SPI - M14	0,893 Kg/m	27
20SP – M76	0,578 Kg/m	11	SPI - M15	1,102 Kg/m	27
20SP – M77	0,576 Kg/m	06	SPI - M16	0,698 Kg/m	32
20SP – M78	0,362 Kg/m	23	SPI - M17	0,994 Kg/m	28
20SP – M85	0,535 Kg/m	06	SPI - M18	0,791 Kg/m	27
20SP – M87	0,361 Kg/m	10	SPI - M56	0,960 Kg/m	33
20SP – M89	0,383 Kg/m	10	SPI - M57	0,980 Kg/m	31
20SP – M90	0,602 Kg/m	06	SPI - M58	0,889 Kg/m	31
20SP – M95	0,611 Kg/m	04	SPI - M59	0,656 Kg/m	31
20SP – M96	0,247 Kg/m	21	SPI - M60	0,599 Kg/m	33
20SP – P01	0,246 Kg/m	21	SPI - M61	0,871 Kg/m	30
CM - 060	0,174 Kg/m	03	SPI - M62	0,894 Kg/m	30
CM - 200	0,173 Kg/m	03	SPI - M63	0,495 Kg/m	34
DS - 238	0,521 Kg/m	36	SPI - M64	0,558 Kg/m	34
MH - 017	0,193 Kg/m	03	SPI - M98	1,149 Kg/m	28
MN - 015	0,881 Kg/m	36	SPI - M99	0,765 Kg/m	32
MN - 055	0,371 Kg/m	36			

CM - 060

Contramarco
0,174 Kg/m

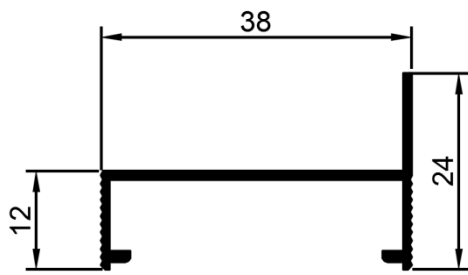

CM - 200

Contramarco
0,173 Kg/m

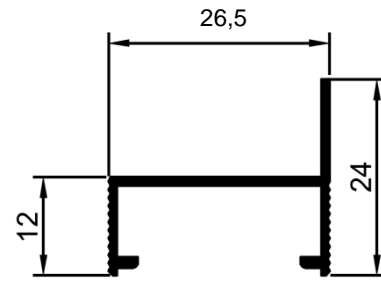

20SP - M18

Arremate
0,173 Kg/m

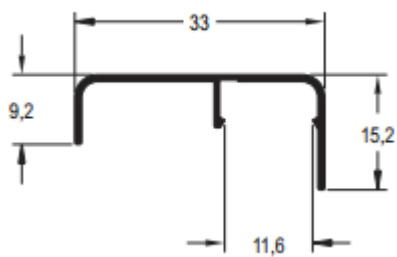

20SP - 202

Presilha para arremate
0,080 Kg/m

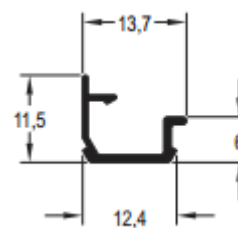

MP - 347

Arremate
0,200 Kg/m

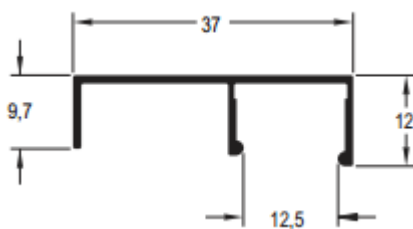

MH - 017

Marco superior 2 planos
0,193 Kg/m

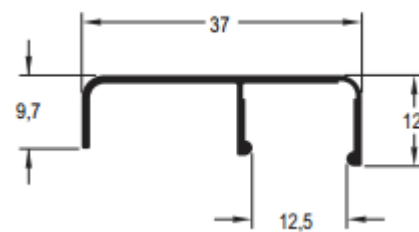

20SP – M02

Marco superior 2 planos
0,596 Kg/m

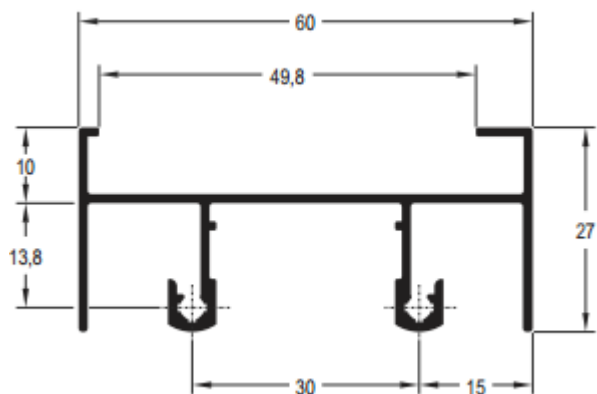

20SP – M41

Marco intermediário – Maxim-ar
1,081 Kg/m

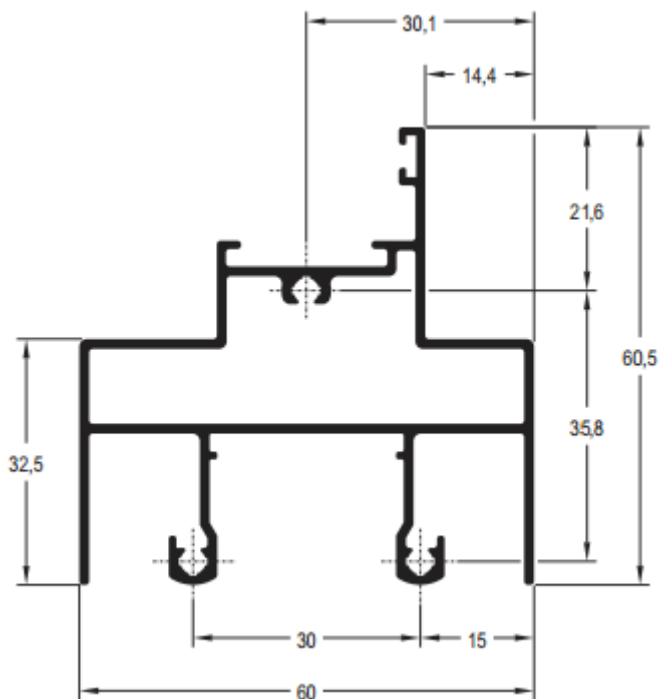

20SP – M01

Marco inferior 2 planos
0,674 Kg/m

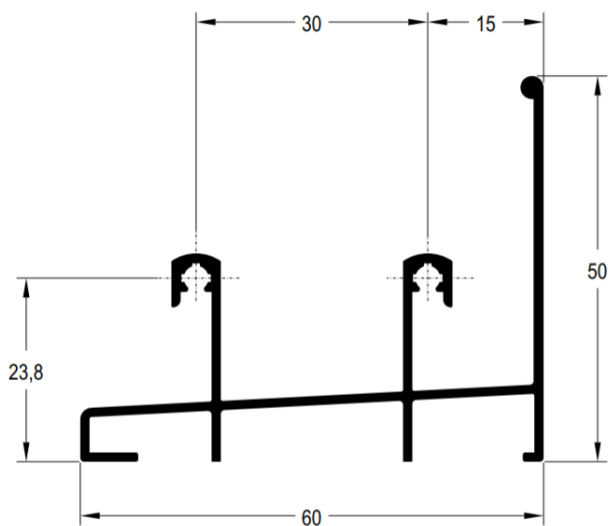

20SP – M95

Marco inferior 2 planos
0,611 Kg/m

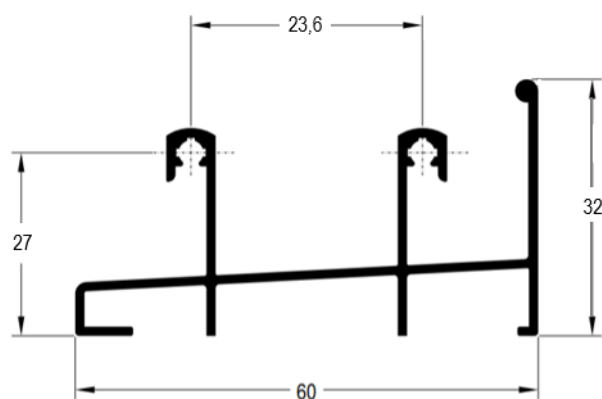

20SP – M03

Marco lateral 2 planos
0,382 Kg/m

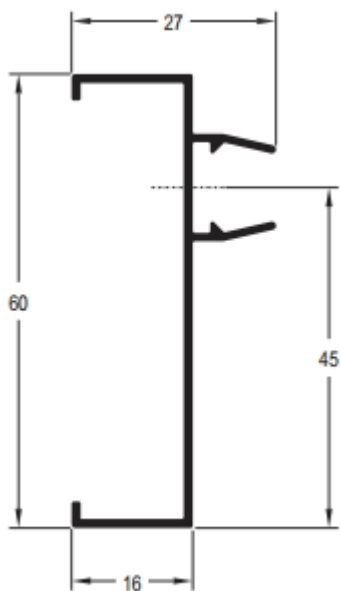

20SP – M19

Mata junta lateral do marco
0,138 Kg/m

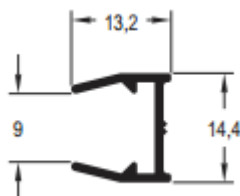

20SP – M43

Marco lateral Maxim-ar
0,352 Kg/m

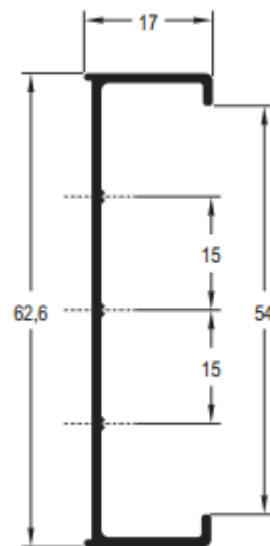

20SP – M39

Marco intermediário – Peitoril
0,999 Kg/m

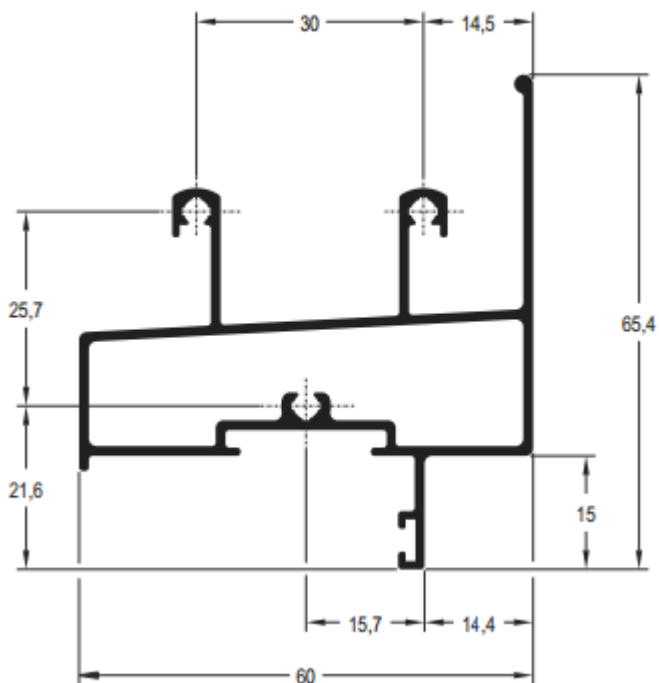

20SP – M40

Marco lateral Maxim-ar
0,493 Kg/m

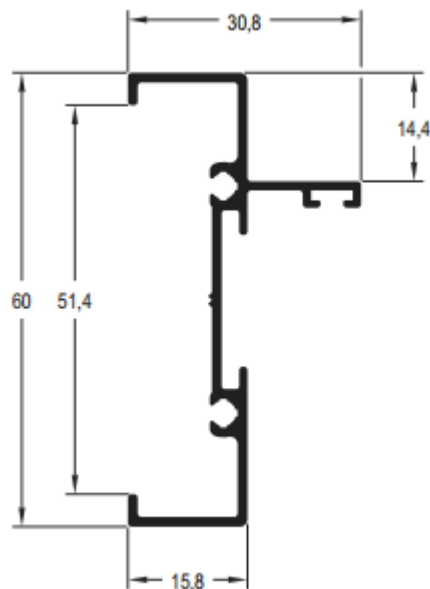

*dimensões em milímetros

20SP – M78

Marco superior 2 planos - Tela
0,362 Kg/m

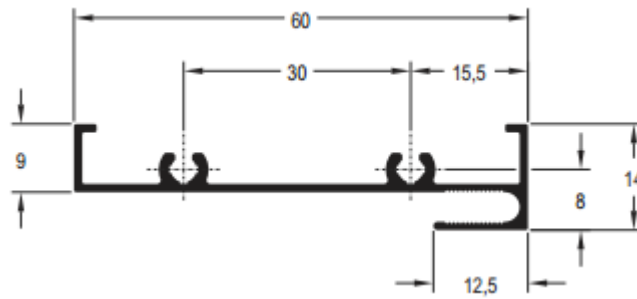

20SP – M76

Marco superior 2 planos - Tela
0,578 Kg/m

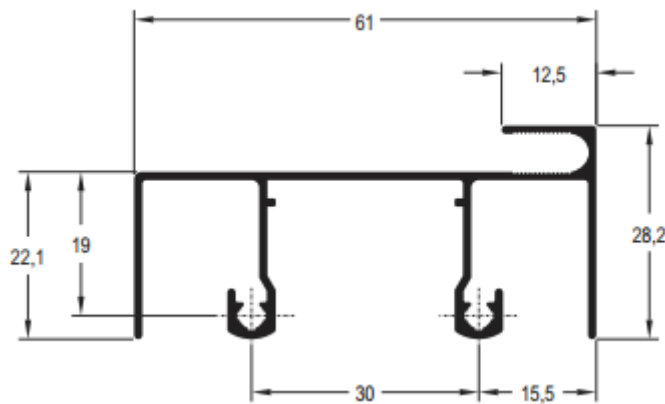

20SP – M89

Trilho inferior - Soleira
0,383 Kg/m

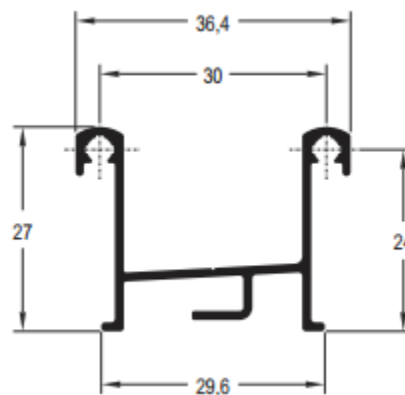

20SP – M05

Marco superior 3 planos
0,786 Kg/m

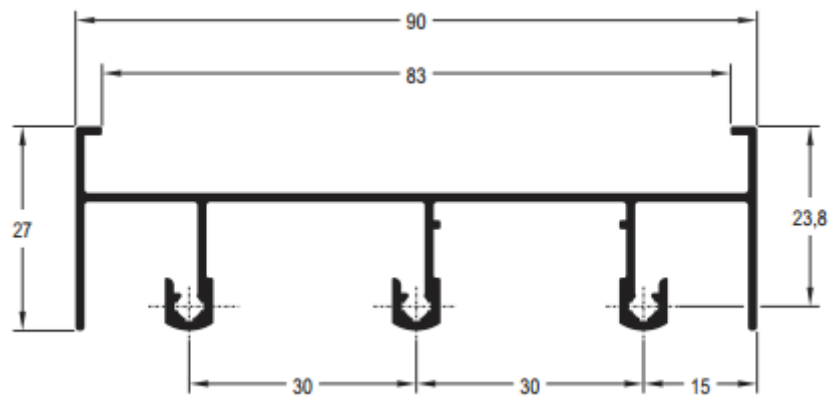
**20SP – M04**

Marco inferior 3 planos
0,888 Kg/m

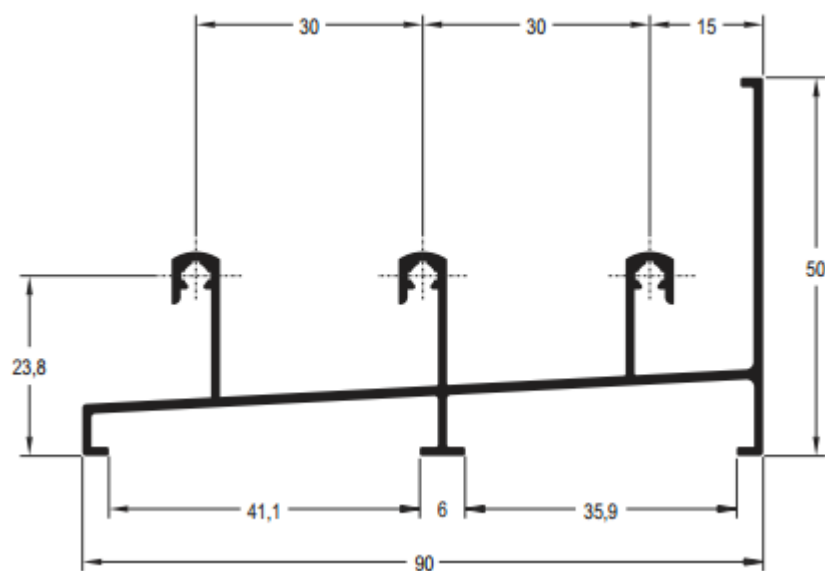

*dimensões em milímetros

MARCO (pacote)

20SP – M06

Marco lateral 3 planos
0,470 Kg/m

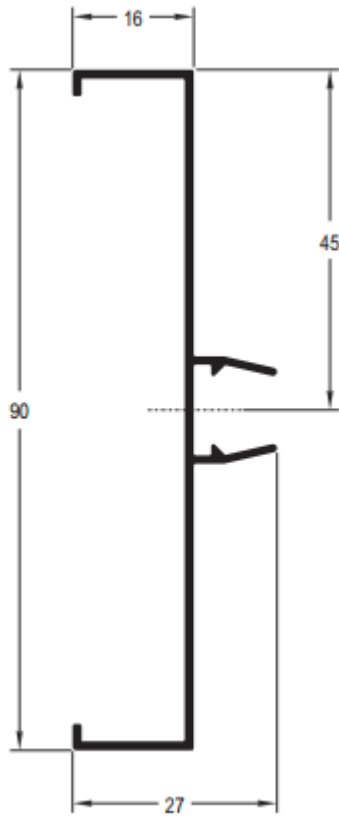

20SP – M07

Marco lateral 3 planos
0,555 Kg/m

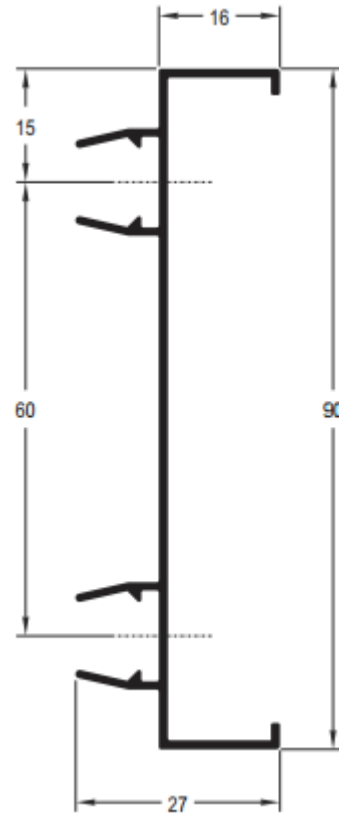

20SP – M90

Marco inferior 3 planos
0,602 Kg/m

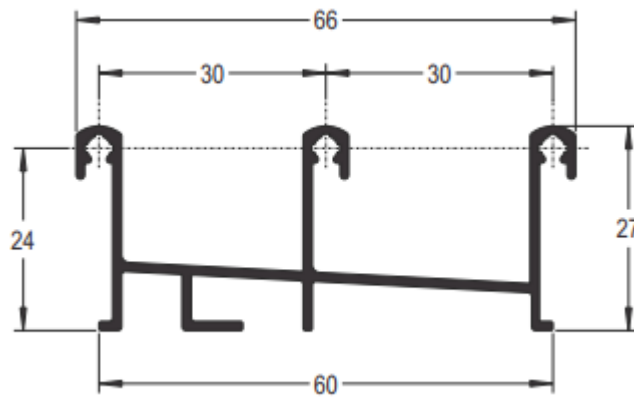

*dimensões em milímetros

20SP – M66

Marco superior 2 planos
0,730 Kg/m

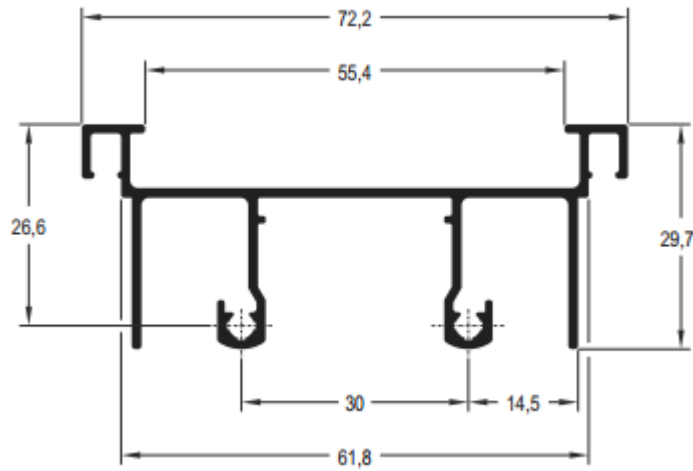

20SP – M67

Marco inferior 2 planos
0,674 Kg/m

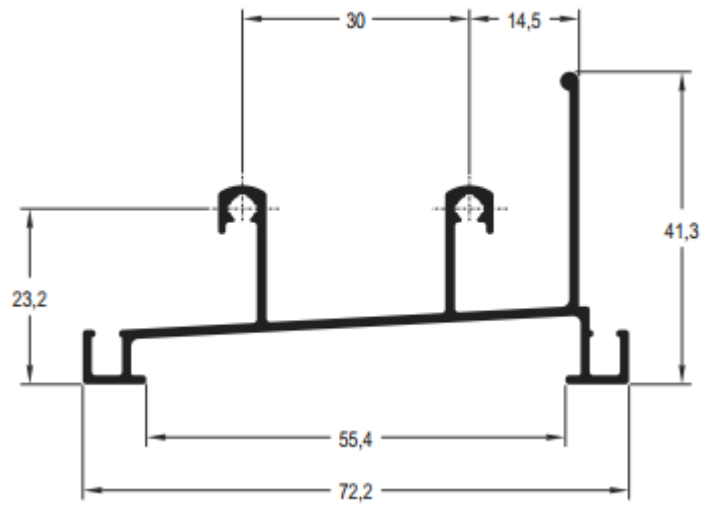

20SP – M65

Marco inferior 2 planos - Porta
0,725 Kg/m

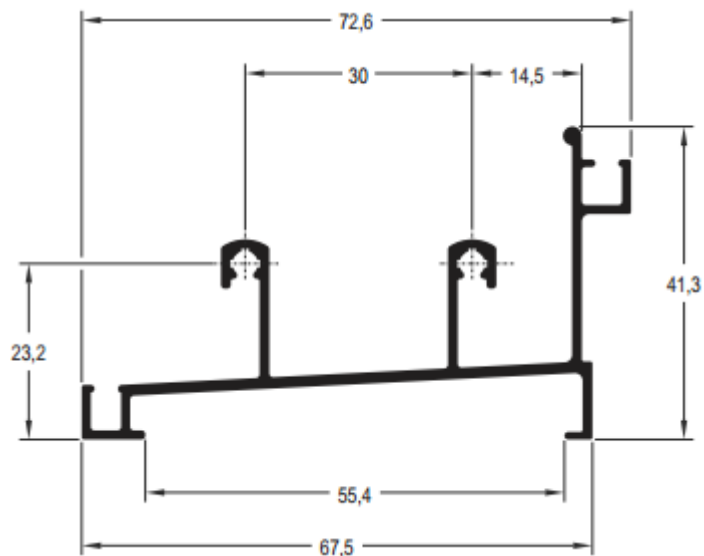

20SP – M85

Marco superior – Bandeira Maxim-ar
0,535 Kg/m

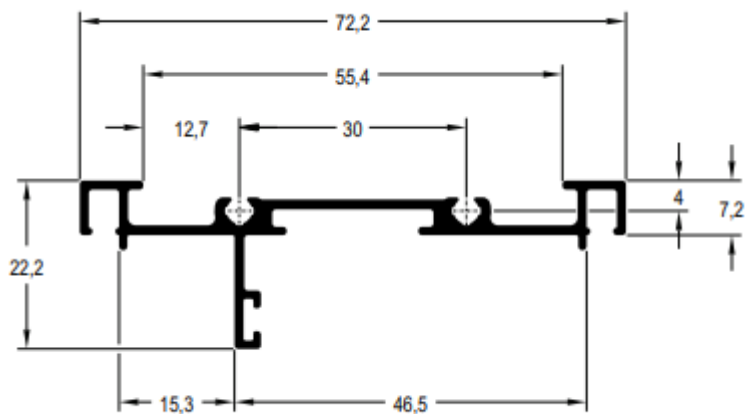

20SP – M68

Marco lateral – 2 planos
0,442 Kg/m

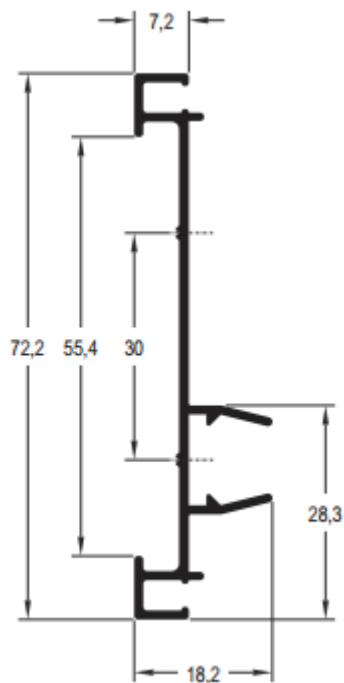

20SP – M87

Marco lateral – 2 planos
0,361 Kg/m

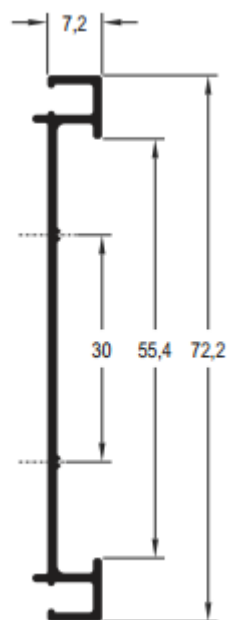

20SP – M74

Marco superior 2 planos
0,436 Kg/m

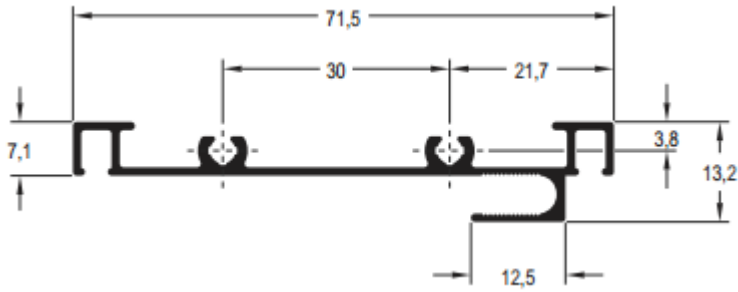

20SP – M75

Marco
0,247 Kg/m

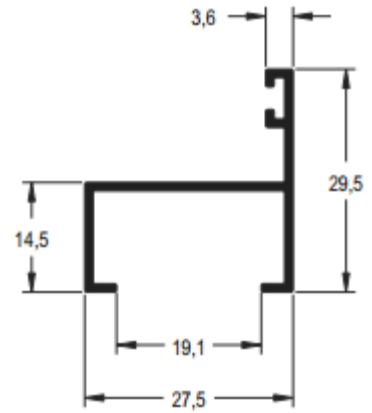

20SP – M37

Marco superior 3 planos
0,964 Kg/m

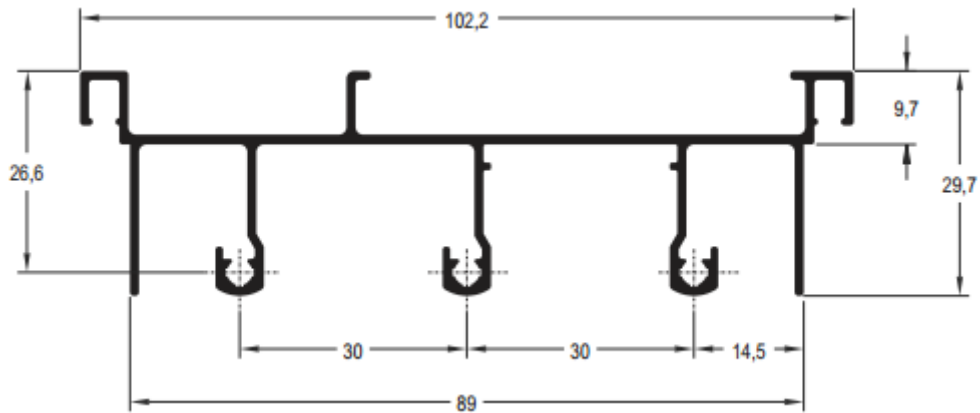

20SP – M38

Marco inferior 3 planos
0,921 Kg/m

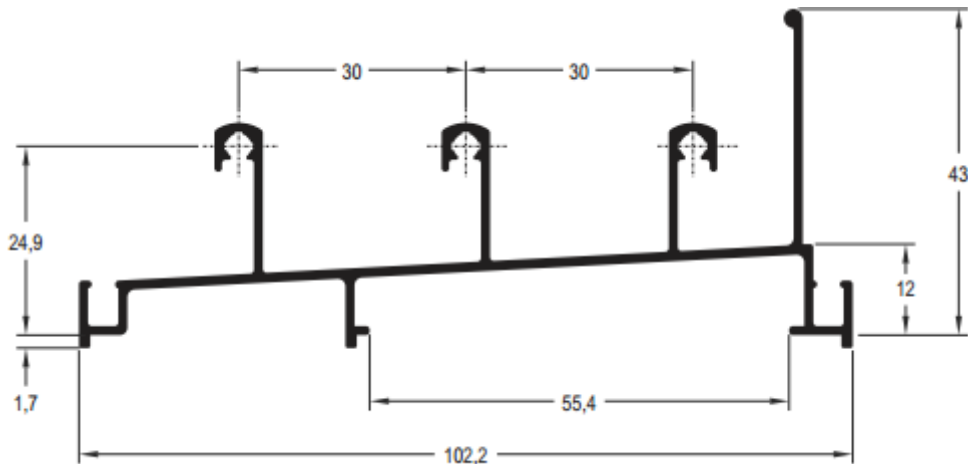

20SP – M36

Marco lateral 3 planos
0,651 Kg/m

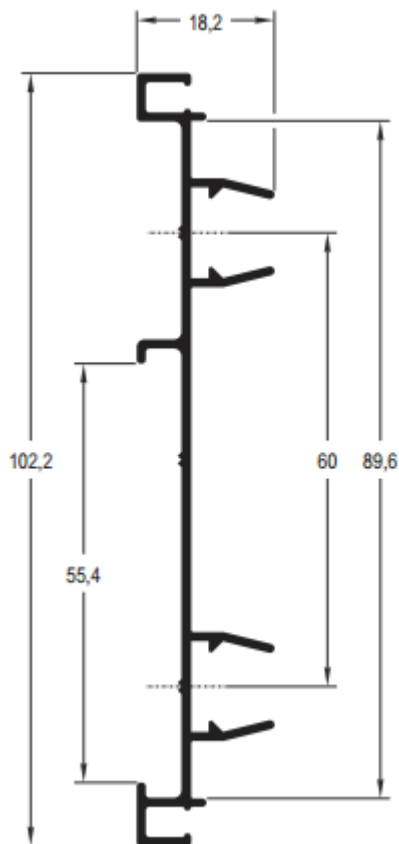

20SP – M35

Marco lateral 3 planos
0,568 Kg/m

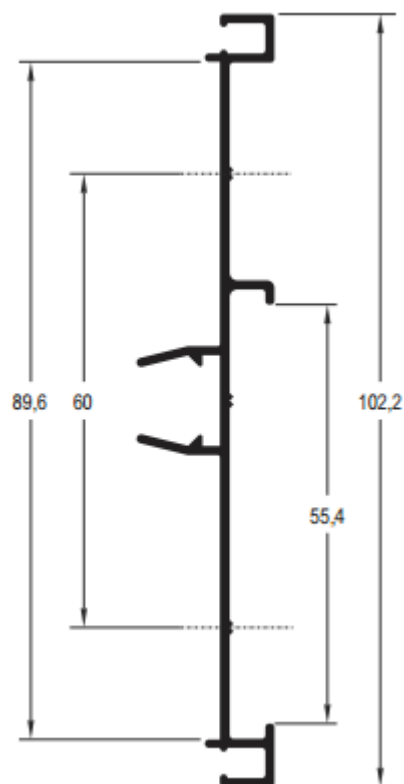

20SP – M69

Mata junta lateral do marco
0,138 Kg/m

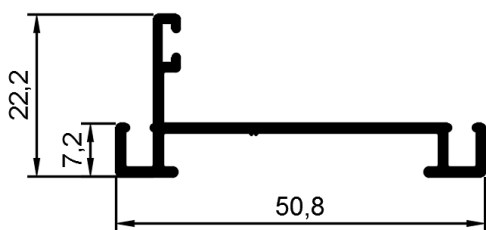

20SP – M70

Marco lateral – Maxim-ar
0,493 Kg/m

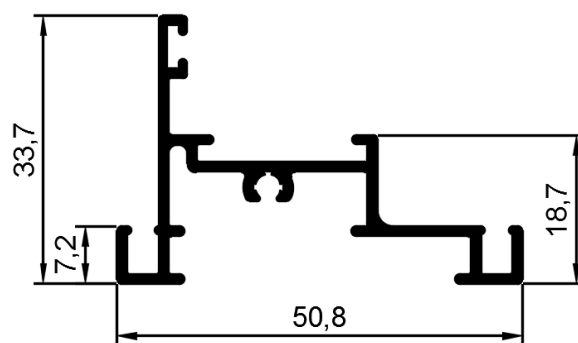

20SP – F01

Montante da folha
0,422 Kg/m

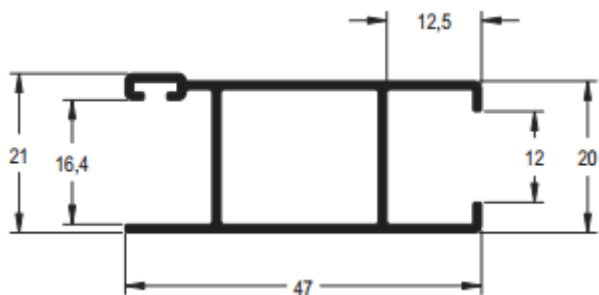

$J_x = 1,127 \text{ cm}^4$	$W_x = 1,067 \text{ cm}^3$
$J_y = 2,959 \text{ cm}^4$	$W_y = 1,251 \text{ cm}^3$

20SP – F02

Montante da folha
0,422 Kg/m

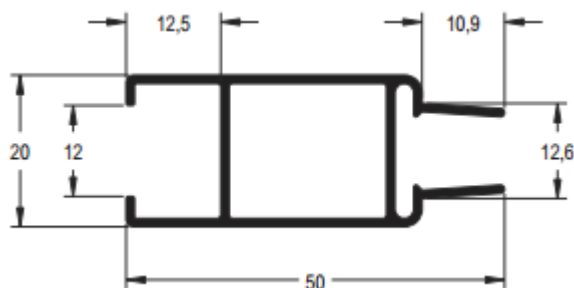

$J_x = 1,007 \text{ cm}^4$	$W_x = 1,007 \text{ cm}^3$
$J_y = 3,233 \text{ cm}^4$	$W_y = 1,266 \text{ cm}^3$

20SP – F03

Montante mão de amigo
0,399 Kg/m

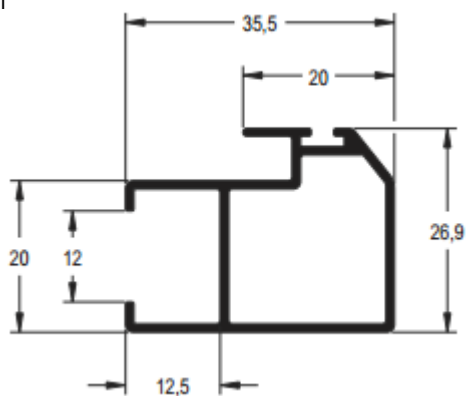

$J_x = 1,375 \text{ cm}^4$	$W_x = 0,973 \text{ cm}^3$
$J_y = 1,720 \text{ cm}^4$	$W_y = 0,867 \text{ cm}^3$

20SP – F04

Montante mão de amigo
0,464 Kg/m

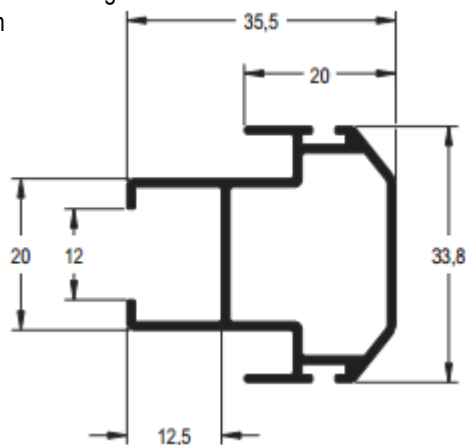

$J_x = 2,144 \text{ cm}^4$	$W_x = 1,268 \text{ cm}^3$
$J_y = 1,832 \text{ cm}^4$	$W_y = 0,893 \text{ cm}^3$

20SP – F08

Montante mão de amigo
0,972 Kg/m

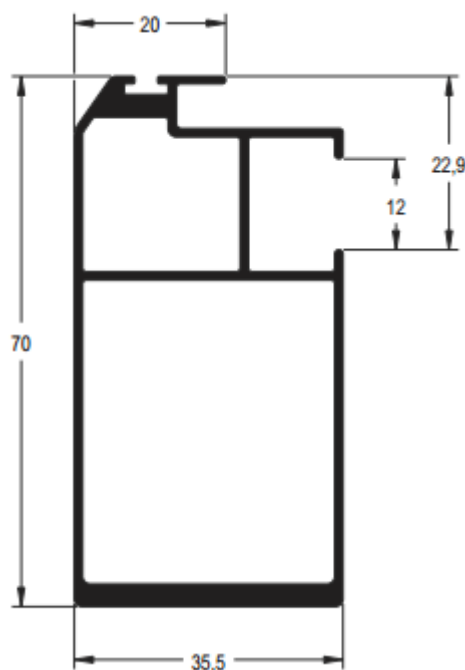

$J_x = 23,668 \text{ cm}^4$	$W_x = 6,286 \text{ cm}^3$
$J_y = 5,670 \text{ cm}^4$	$W_y = 2,967 \text{ cm}^3$

20SP – F07

Montante mão de amigo
0,580 Kg/m

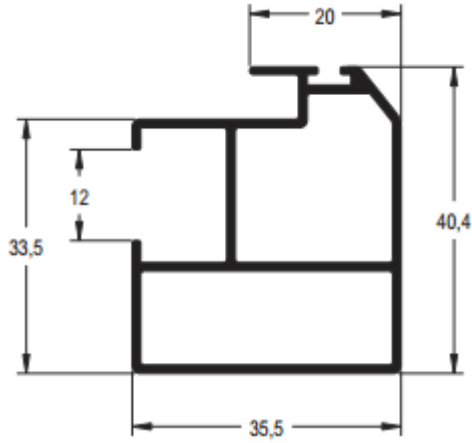

$Jx= 3,880 \text{ cm}^4$	$Wx= 1,826 \text{ cm}^3$
$Jy= 2,965 \text{ cm}^4$	$Wy= 1,546 \text{ cm}^3$

20SP – F06

Montante da folha
0,602 Kg/m

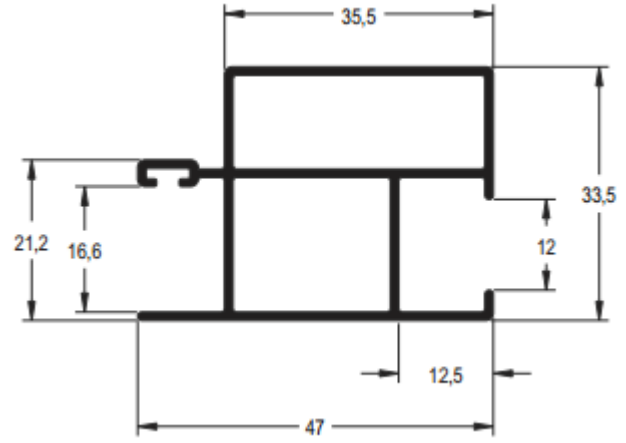

$Jx= 3,037 \text{ cm}^4$	$Wx= 1,769 \text{ cm}^3$
$Jy= 4,335 \text{ cm}^4$	$Wy= 1,725 \text{ cm}^3$

20SP – F12

Montante da folha
0,826 Kg/m

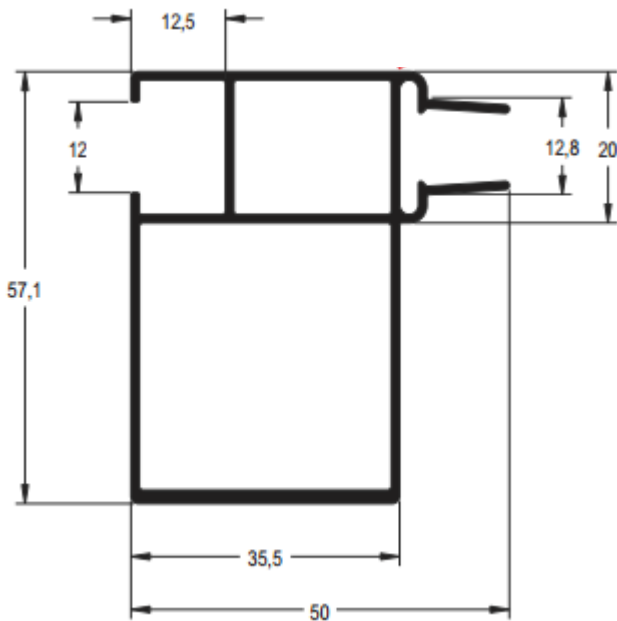

$Jx= 12,830 \text{ cm}^4$	$Wx= 4,219 \text{ cm}^3$
$Jy= 6,553 \text{ cm}^4$	$Wy= 2,286 \text{ cm}^3$

20SP – F11

Montante da folha
0,808 Kg/m

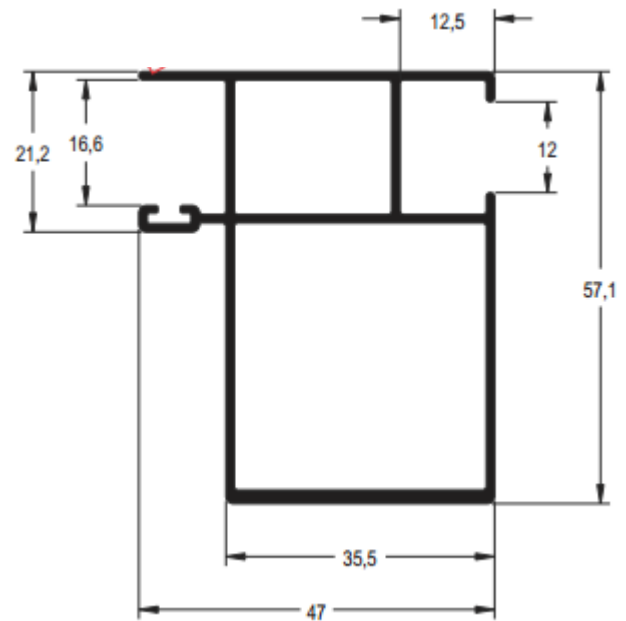

$Jx= 12,494 \text{ cm}^4$	$Wx= 4,199 \text{ cm}^3$
$Jy= 6,182 \text{ cm}^4$	$Wy= 2,363 \text{ cm}^3$

20SP – F90

Montante vertical da folha
0,347 Kg/m

SOB ENCOMENDA

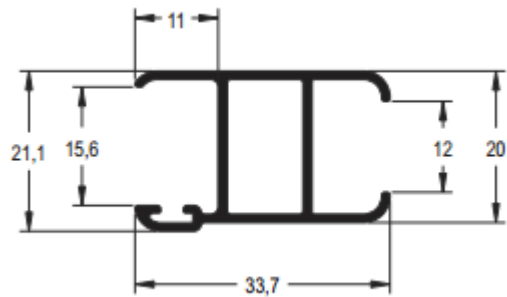
**20SP – F91**

Montante engate interno
0,346 Kg/m

SOB ENCOMENDA

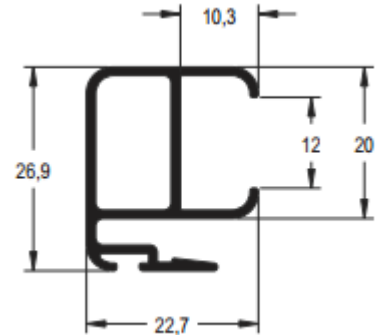
**20SP – F92**

Montante engate interno/externo
0,439 Kg/m

SOB ENCOMENDA

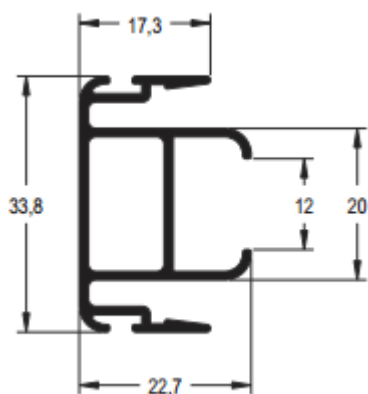
**20SP – F85**

Travessa da folha
0,350 Kg/m

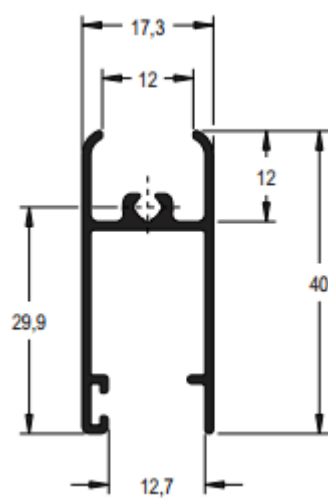

20SP – F09

Travessa da folha
0,520 Kg/m

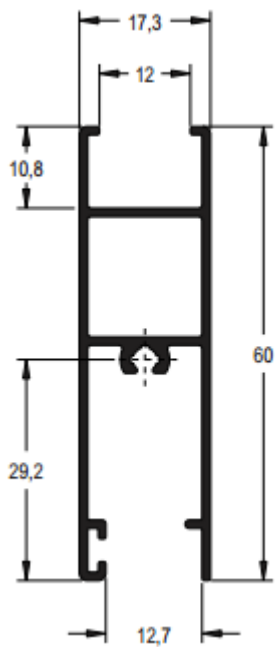

20SP – F05

Travessa da Folha
0,373 Kg/m

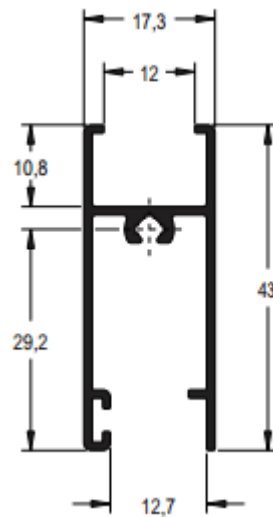

20SP – F10

Travessa intermediária
0,350 Kg/m

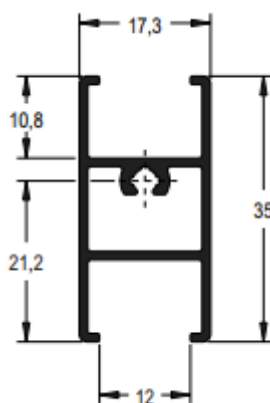

20SP – F42

Montante da folha
0,420 Kg/m

SOB ENCOMENDA

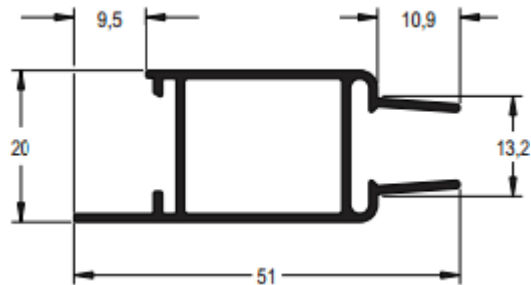

$J_x = 0,929 \text{ cm}^4$	$W_x = 0,869 \text{ cm}^3$
$J_y = 2,670 \text{ cm}^4$	$W_y = 0,993 \text{ cm}^3$

20SP – F43

Montante da folha
0,401 Kg/m

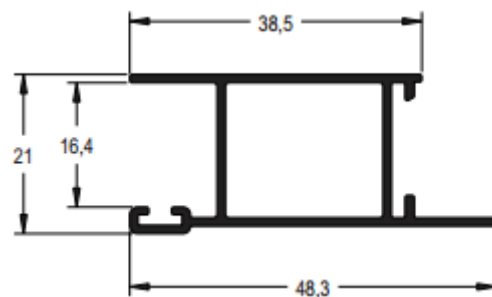

$J_x = 1,040 \text{ cm}^4$	$W_x = 0,929 \text{ cm}^3$
$J_y = 2,452 \text{ cm}^4$	$W_y = 0,931 \text{ cm}^3$

20SP – F50

Montante mão de amigo
0,080 Kg/m

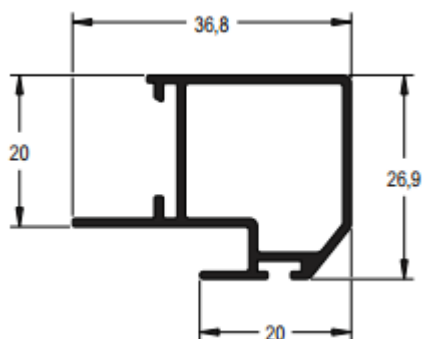

$J_x = 1,228 \text{ cm}^4$	$W_x = 0,895 \text{ cm}^3$
$J_y = 1,368 \text{ cm}^4$	$W_y = 0,611 \text{ cm}^3$

20SP – F48

Montante mão de amigo
0,200 Kg/m

SOB ENCOMENDA

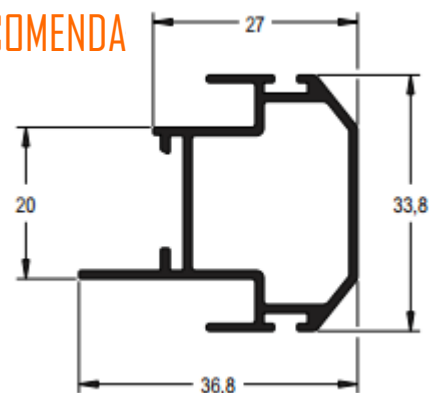

$J_x = 12,494 \text{ cm}^4$	$W_x = 4,199 \text{ cm}^3$
$J_y = 6,182 \text{ cm}^4$	$W_y = 2,363 \text{ cm}^3$

20SP – F59

Montante mão de amigo
0,378 Kg/m

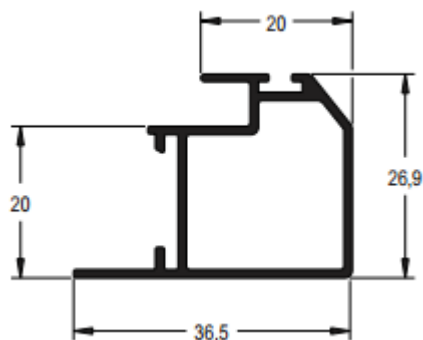

$J_x = 1,356 \text{ cm}^4$	$W_x = 0,919 \text{ cm}^3$
$J_y = 1,368 \text{ cm}^4$	$W_y = 0,611 \text{ cm}^3$

20SP – F57

Montante central
0,584 Kg/m

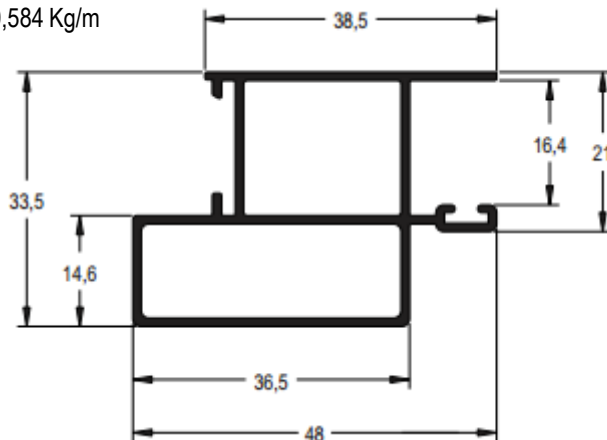

$J_x = 2,823 \text{ cm}^4$	$W_x = 1,646 \text{ cm}^3$
$J_y = 4,016 \text{ cm}^4$	$W_y = 1,645 \text{ cm}^3$

20SP – F55

Montante mão de amigo
0,591 Kg/m

SOB ENCOMENDA

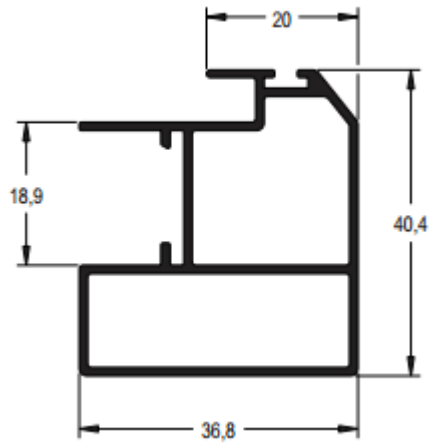

$J_x = 3,962 \text{ cm}^4$	$W_x = 1,858 \text{ cm}^3$
$J_y = 3,041 \text{ cm}^4$	$W_y = 1,498 \text{ cm}^3$

20SP – F54

Montante mão de amigo
0,561 Kg/m

SOB ENCOMENDA

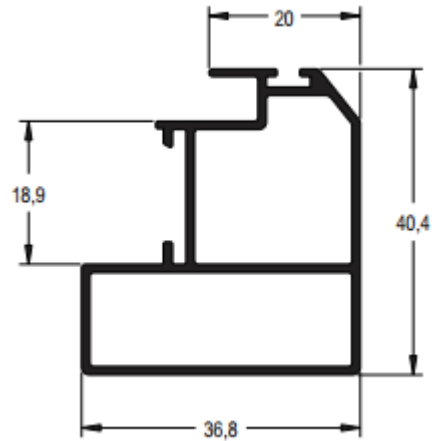

$J_x = 3,742 \text{ cm}^4$	$W_x = 1,697 \text{ cm}^3$
$J_y = 2,764 \text{ cm}^4$	$W_y = 1,310 \text{ cm}^3$

20SP – F56

Montante central
0,669 Kg/m

SOB ENCOMENDA

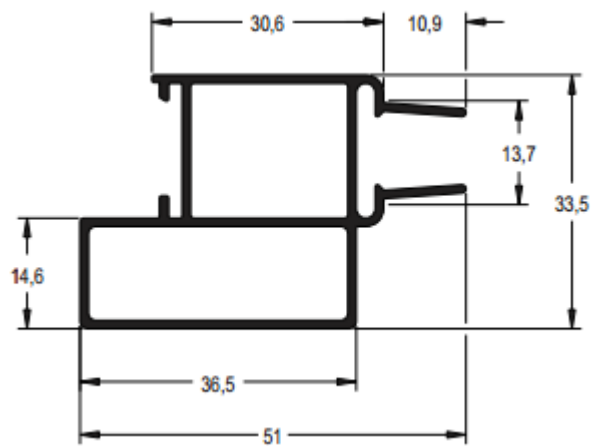

$J_x = 2,831 \text{ cm}^4$	$W_x = 1,676 \text{ cm}^3$
$J_y = 4,334 \text{ cm}^4$	$W_y = 1,620 \text{ cm}^3$

20SP – F44

Montante mão de amigo
0,918 Kg/m

SOB ENCOMENDA

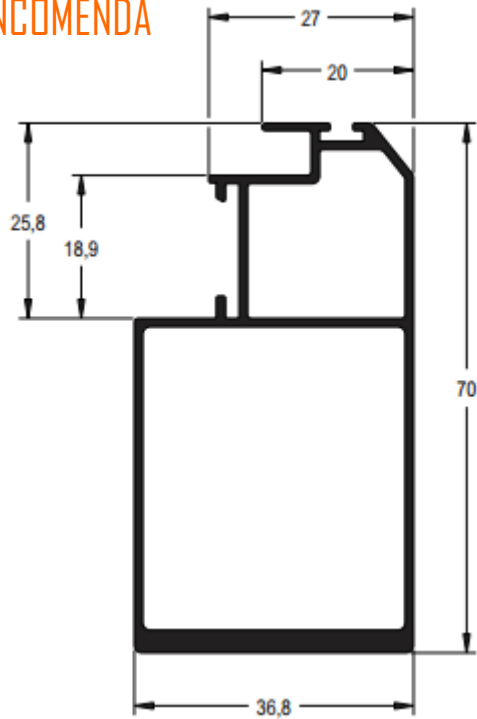

$Jx= 20,816 \text{ cm}^4$	$Wx= 5,118 \text{ cm}^3$
$Jy= 5,575 \text{ cm}^4$	$Wy= 2,781 \text{ cm}^3$

20SP – F45

Montante mão de amigo
0,790 Kg/m

SOB ENCOMENDA

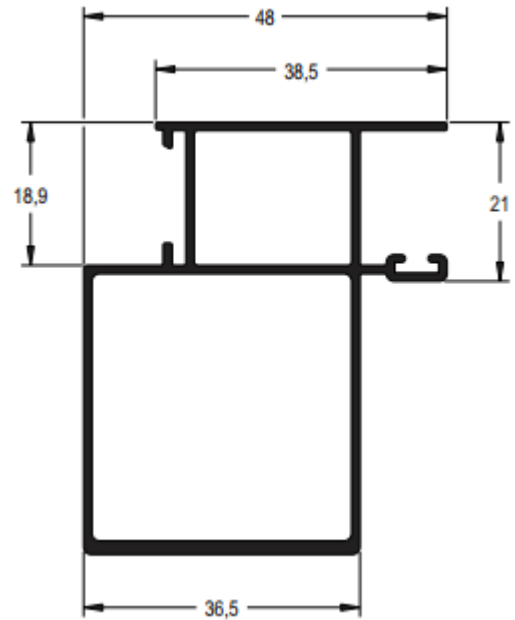

$Jx= 11,963 \text{ cm}^4$	$Wx= 4,168 \text{ cm}^3$
$Jy= 6,039 \text{ cm}^4$	$Wy= 2,340 \text{ cm}^3$

20SP – F46

Montante central
0,810 Kg/m

SOB ENCOMENDA

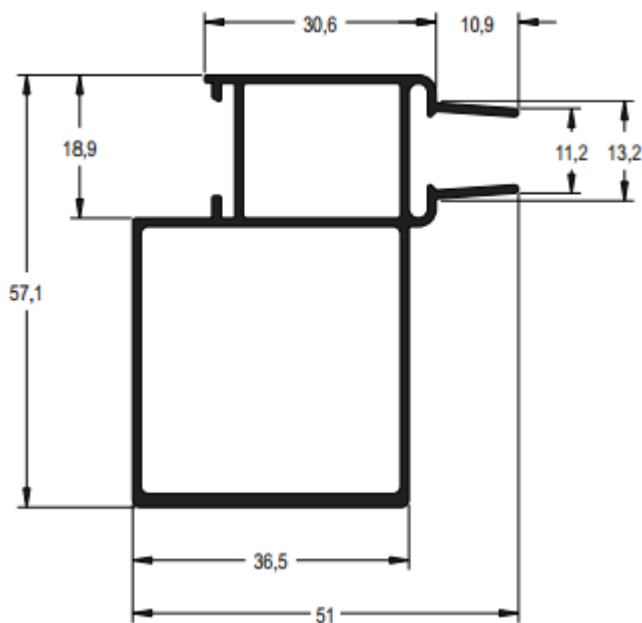

$Jx= 12,327 \text{ cm}^4$	$Wx= 4,194 \text{ cm}^3$
$Jy= 6,404 \text{ cm}^4$	$Wy= 2,265 \text{ cm}^3$

20SP – F58

Montante mão de amigo
0,946 Kg/m

SOB ENCOMENDA

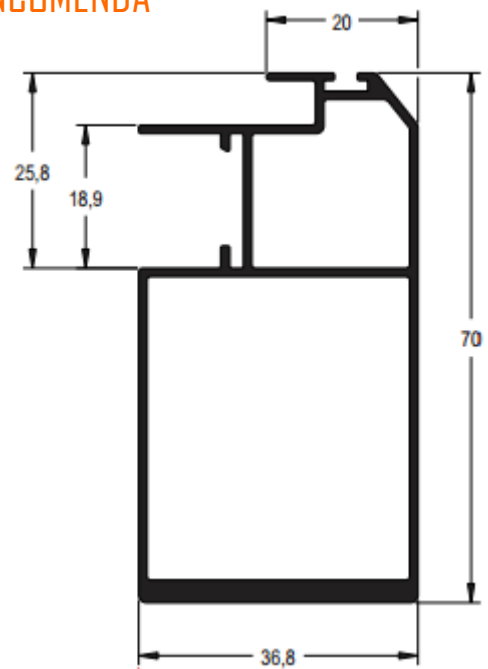

$Jx= 21,940 \text{ cm}^4$	$Wx= 5,537 \text{ cm}^3$
$Jy= 5,797 \text{ cm}^4$	$Wy= 2,960 \text{ cm}^3$

20SP – F51

Travessa inferior
0,484 Kg/m

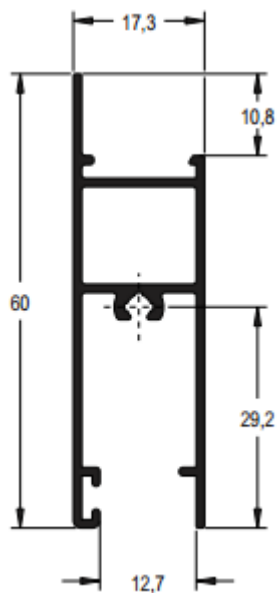

20SP – F52

Travessa da folha
0,350 Kg/m

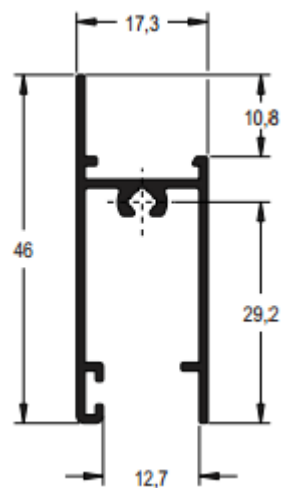

20SP – F49

Travessa intermediária
0,314 Kg/m

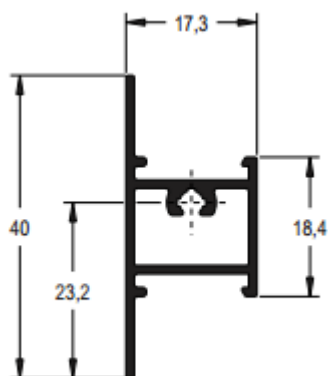

20SP – F35

Baguete
0,097 Kg/m

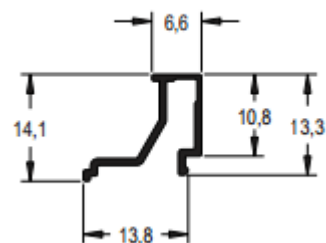

20SP – M24

Marco janela Maxim-ar
0,341 Kg/m

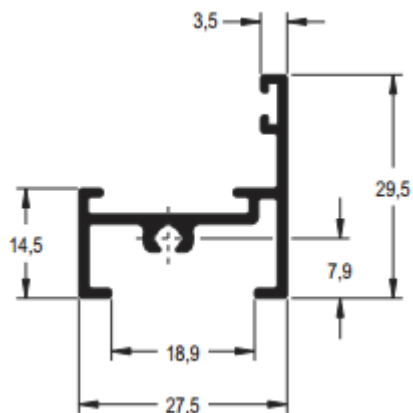

20SP – M96

Arremate
0,143 Kg/m

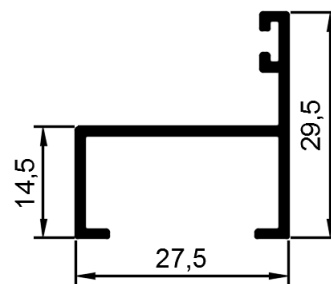

20SP – M25

Travessa janela Maxim-ar
0,552 Kg/m

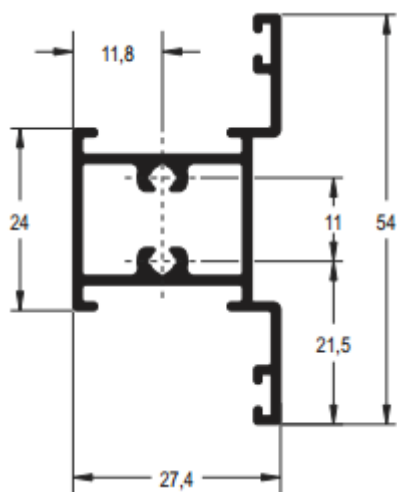

20SP – M71

Arremate
0,200 Kg/m

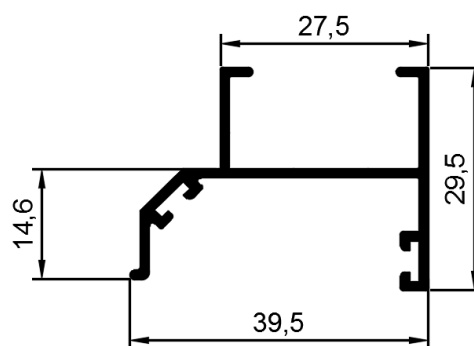

20SP – M30

Travessa superior/inferior – Folha Maxim-ar
0,304 Kg/m

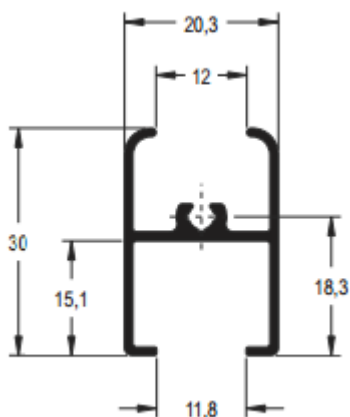

20SP – M29

Montante lateral – Folha maxim-ar
0,273 Kg/m

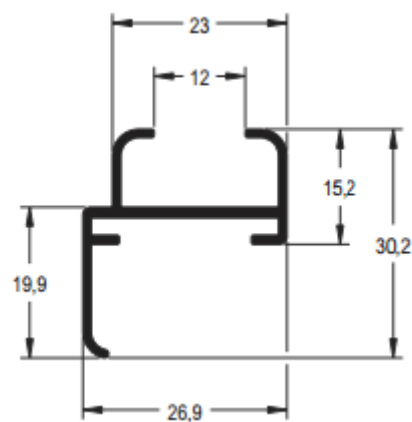

20SP – M22

Travessa superior – Folha Maxim-ar
0,337 Kg/m

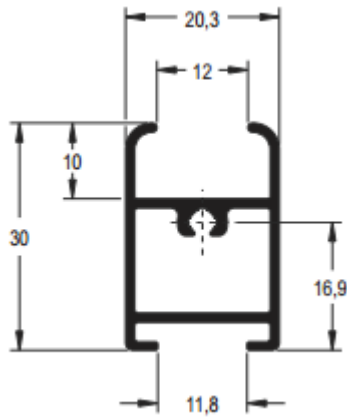

20SP – M21

Folha Maxim-ar
0,417 Kg/m

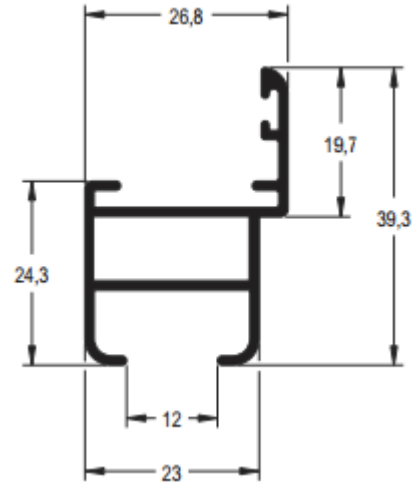

20SP – M31

Complemento travessa inferior
0,135 Kg/m

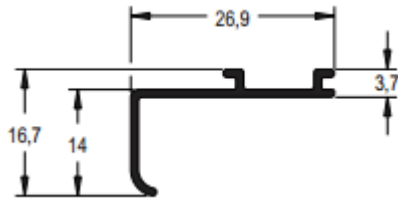

20SP – M23

Pingadeira da folha Maxim-ar
0,173 Kg/m

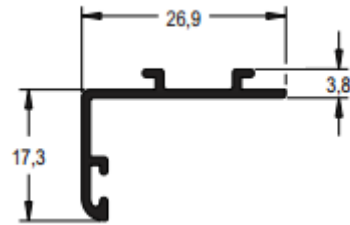

20SP – M28

Pingadeira do marco Maxim-ar
0,162 Kg/m

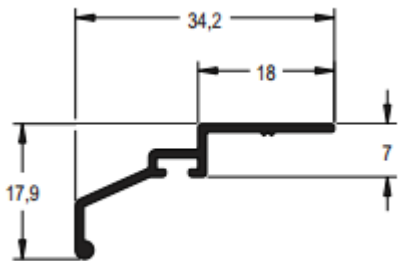

20SP – F34

Baguete
0,161 Kg/m

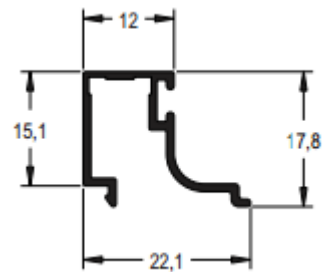

20SP – P01

Palheta
0,264 Kg/m

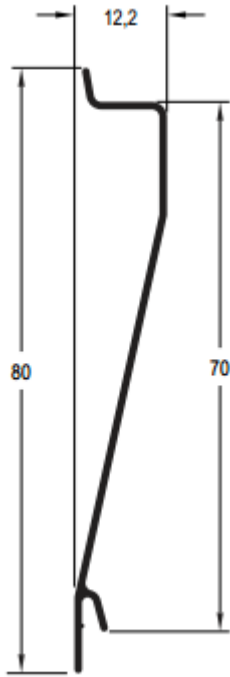

SPA - 101

Palheta
0,290 Kg/m

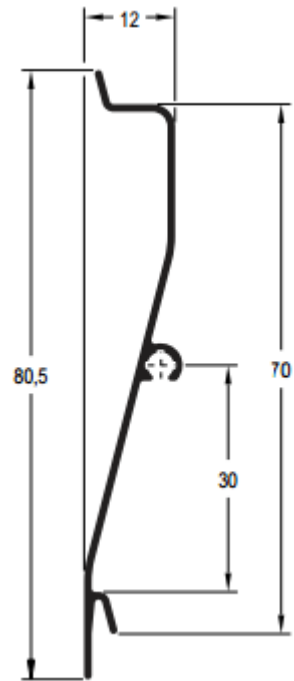

20SP – F20

Complemento
0,135 Kg/m

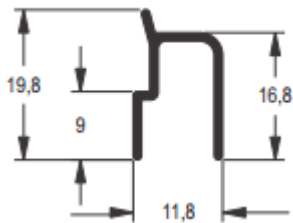

20SP – M77

Pingadeira
0,576 Kg/m

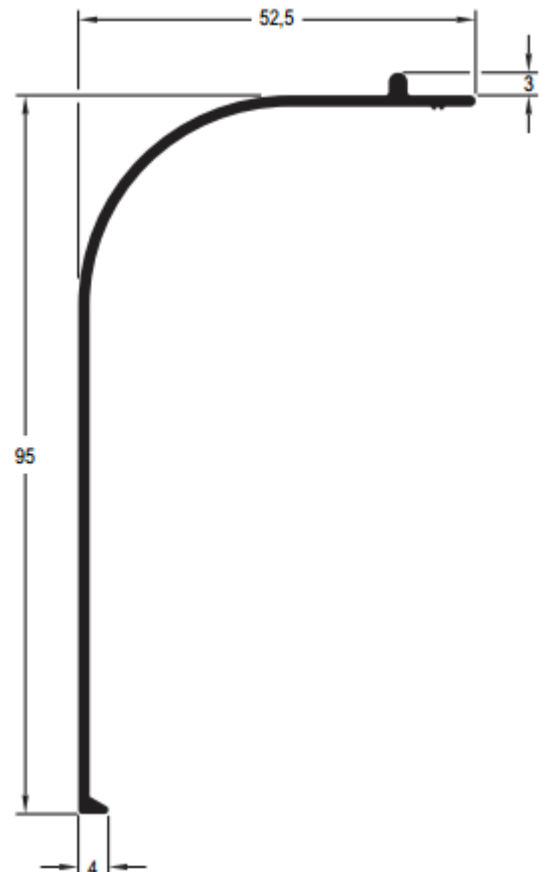

SPA – M111

Marco superior 3 folhas
0,852 Kg/m

SOB ENCOMENDA

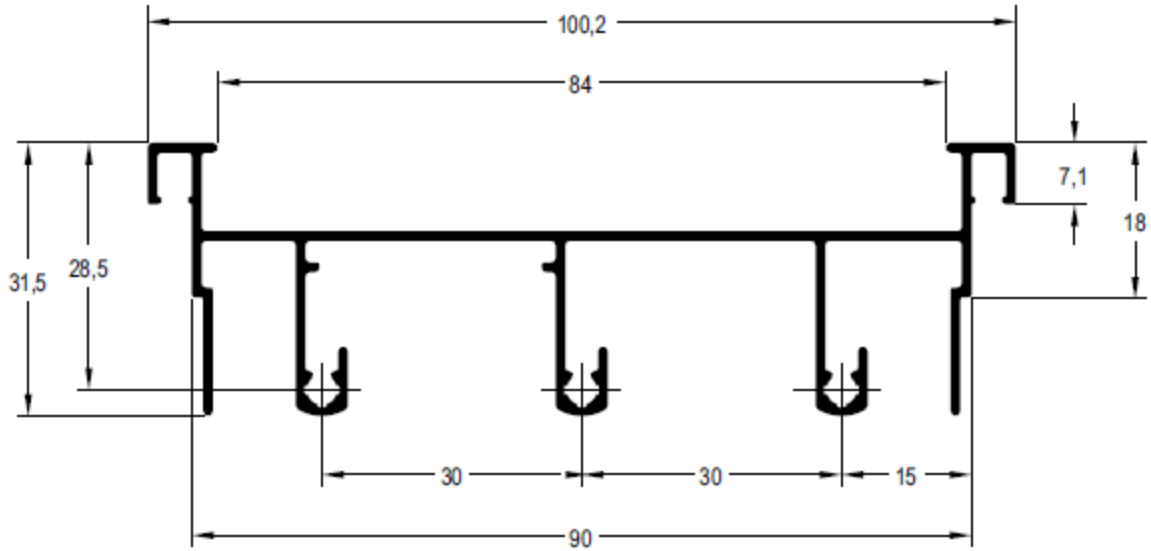

SPA – M108

Marco superior 2 folhas
0,658 Kg/m

SOB ENCOMENDA

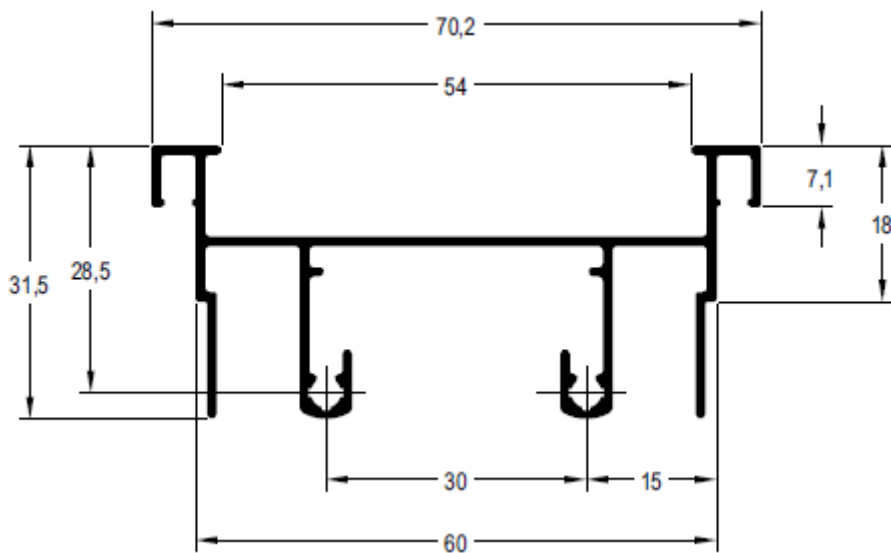

SPA – M103

Complemento
0,135 Kg/m

SOB ENCOMENDA

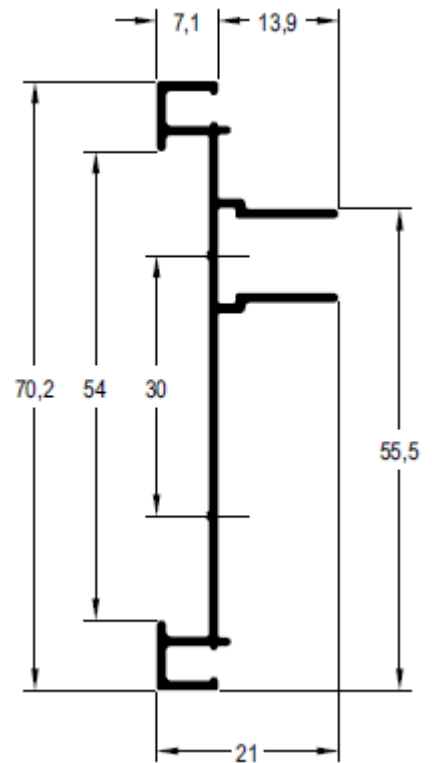

SPA – M113

Marco lateral 3 folhas
0,485 Kg/m

SOB ENCOMENDA

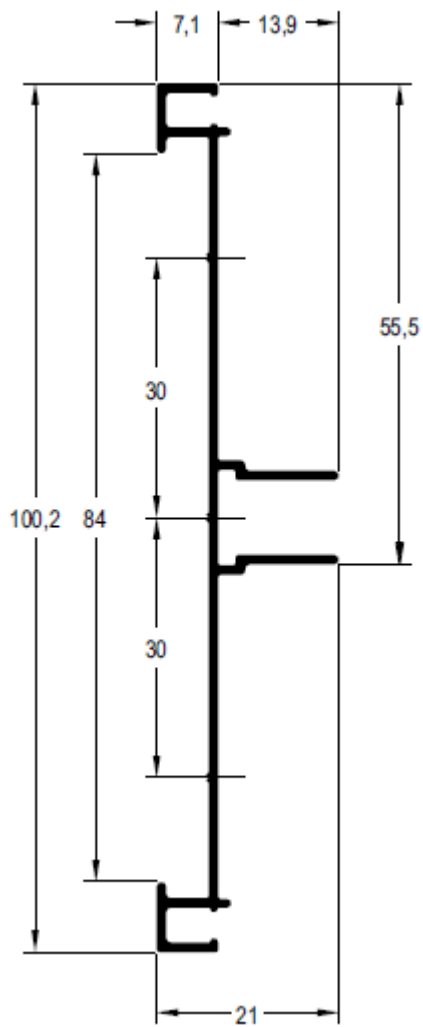

SPA – M114

Marco lateral 3 folhas
0,574 Kg/m

SOB ENCOMENDA

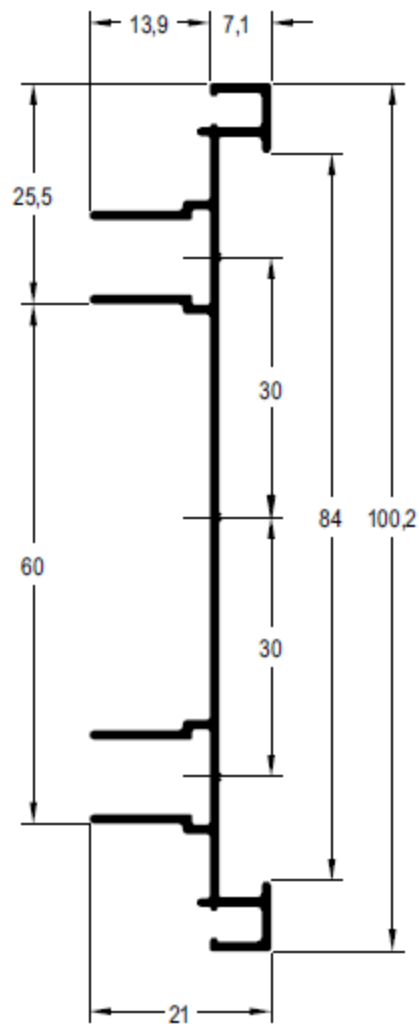

SPA – F109

Travessa inferior da folha
0,909 Kg/m

SOB ENCOMENDA

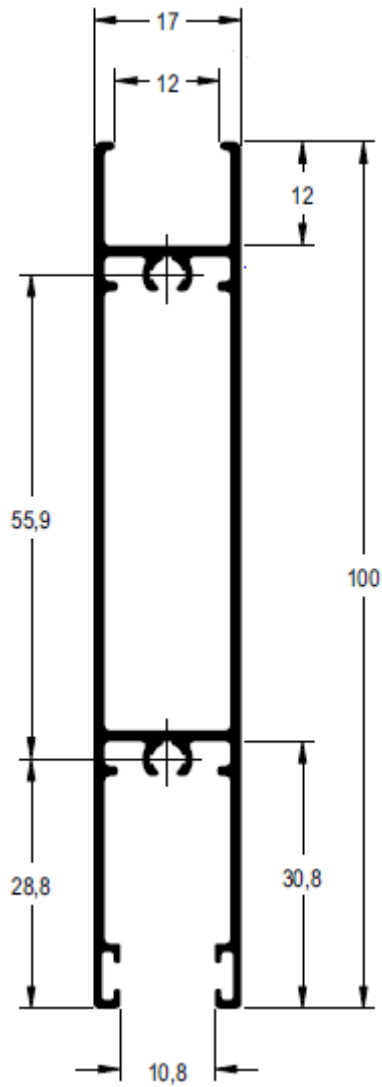

SPA – F105

Travessa superior e inferior da folha
0,367 Kg/m

SOB ENCOMENDA

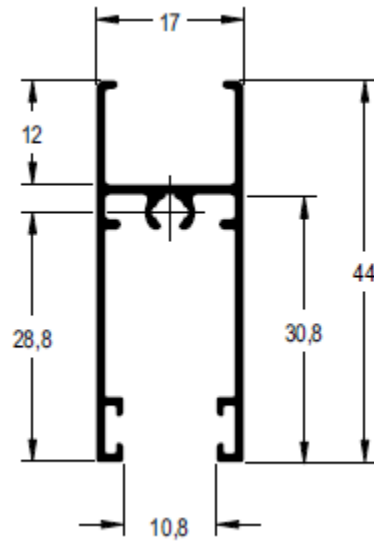

SPI – M14

Marco superior
0,893 Kg/m

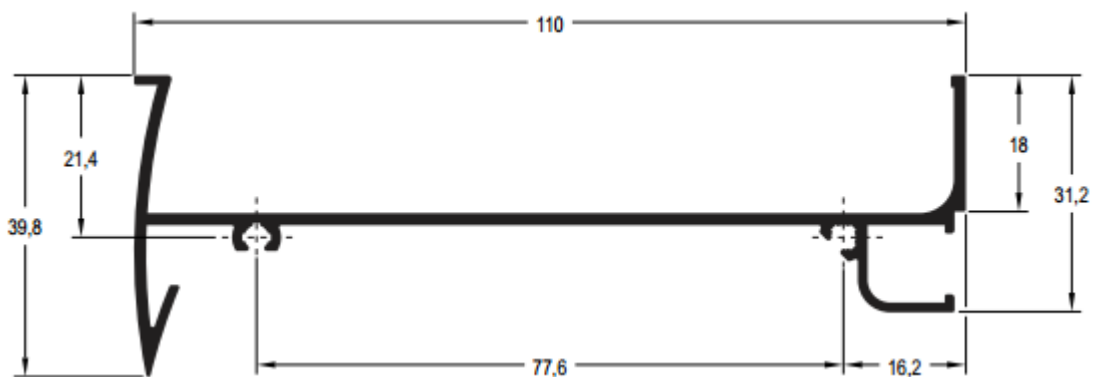

SPI – M15

Travessa intermediária da caixa
1,102 Kg/m

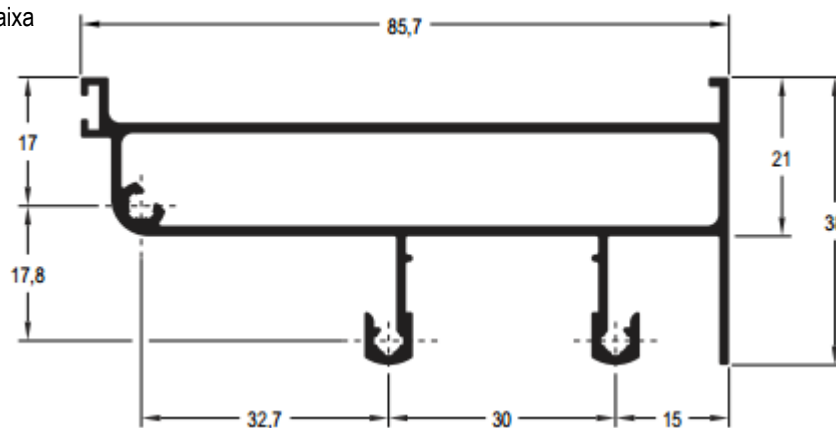

20SP – M59S

Travessa intermediária da caixa
0,660 Kg/m

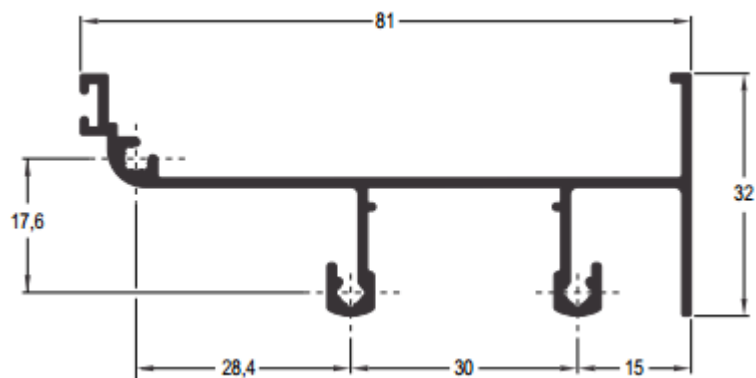

SPI – M18

Marco inferior
0,791 Kg/m

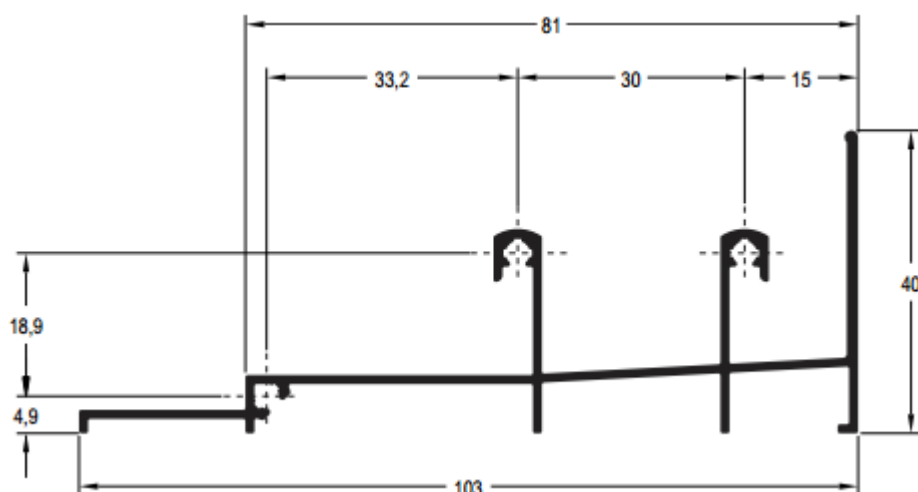

SPI – M17

Tampa interna
0,994 Kg/m

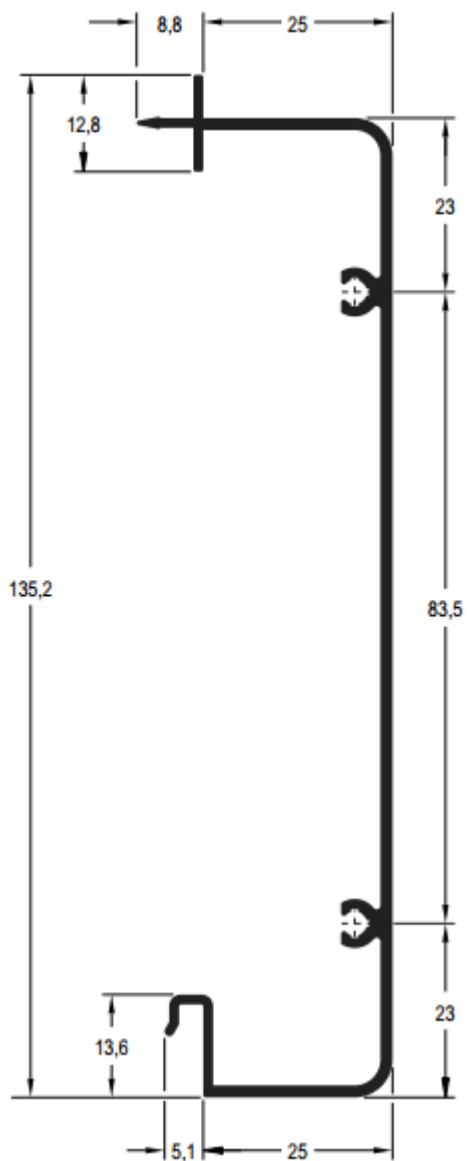

SPI – M98

Tampa interna
1,149 Kg/m

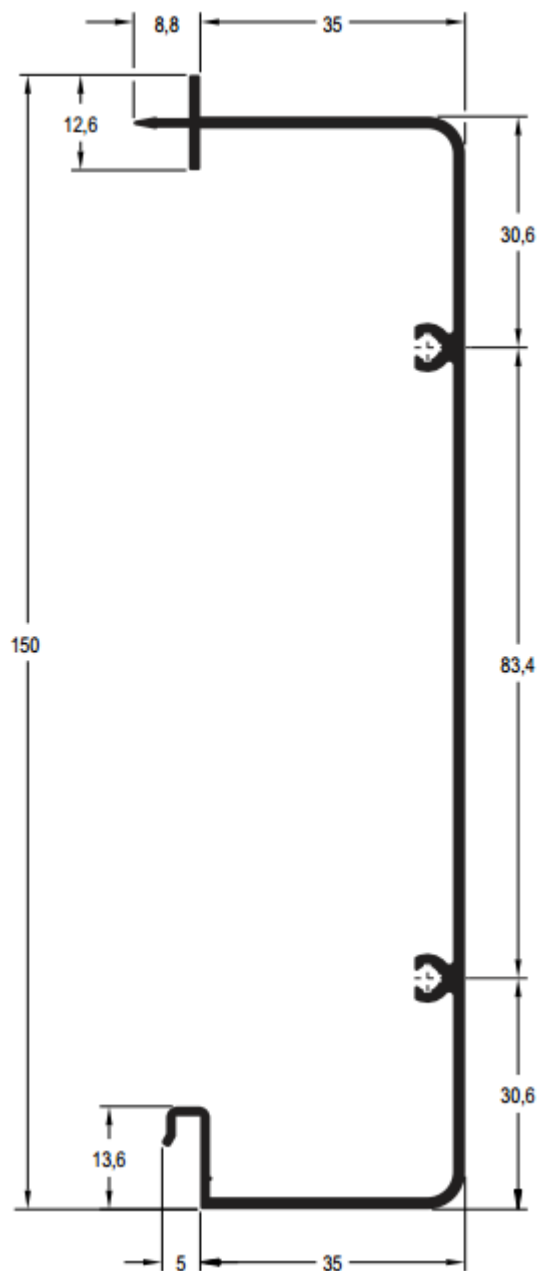

SPI – M11

Marco lateral
0,559 Kg/m

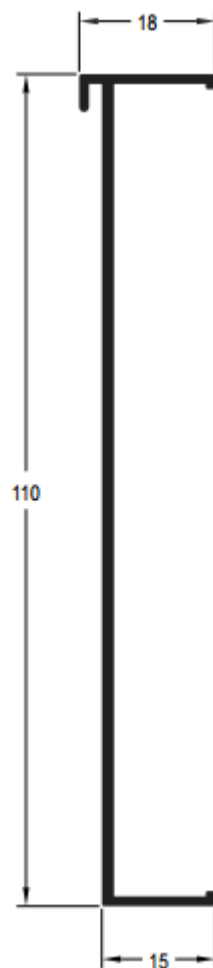

SPI – M61

Tampa interna
0,871 Kg/m

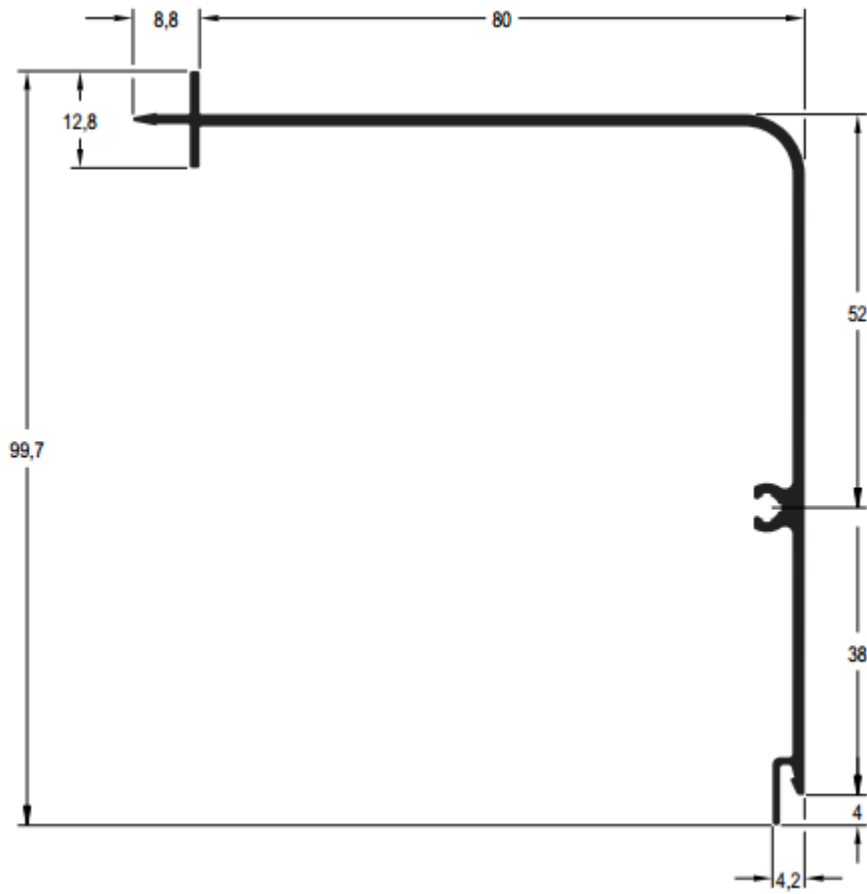

SPI – M62

Tampa interna
0,894 Kg/m

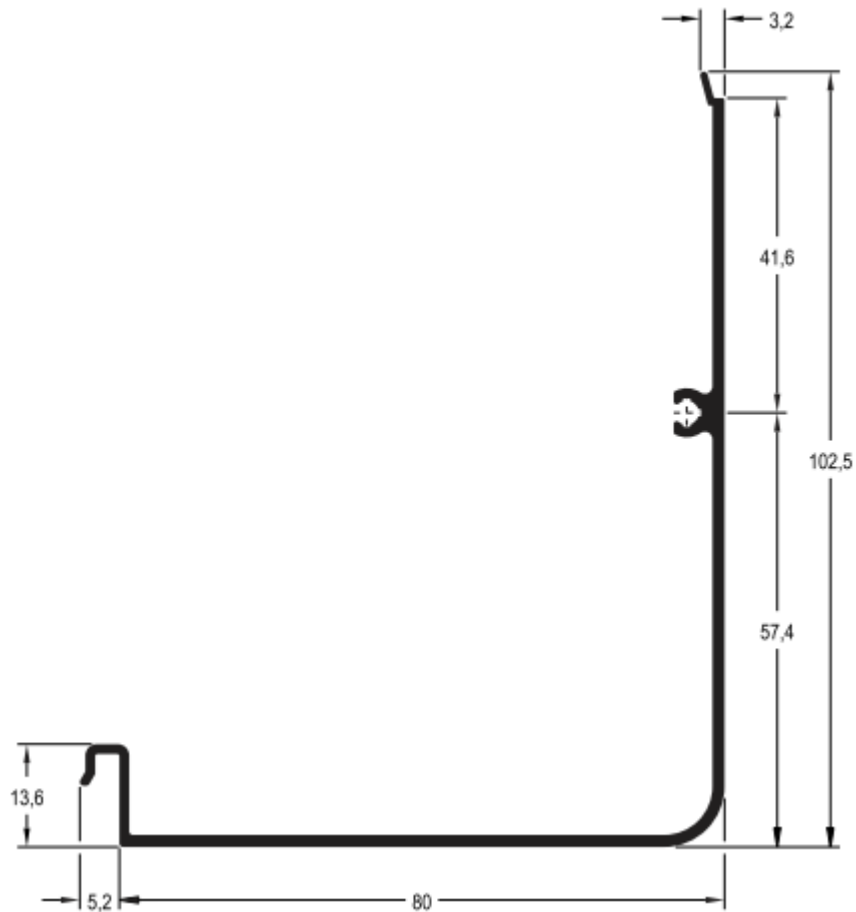

SPI – M58

Marco superior
0,889 Kg/m

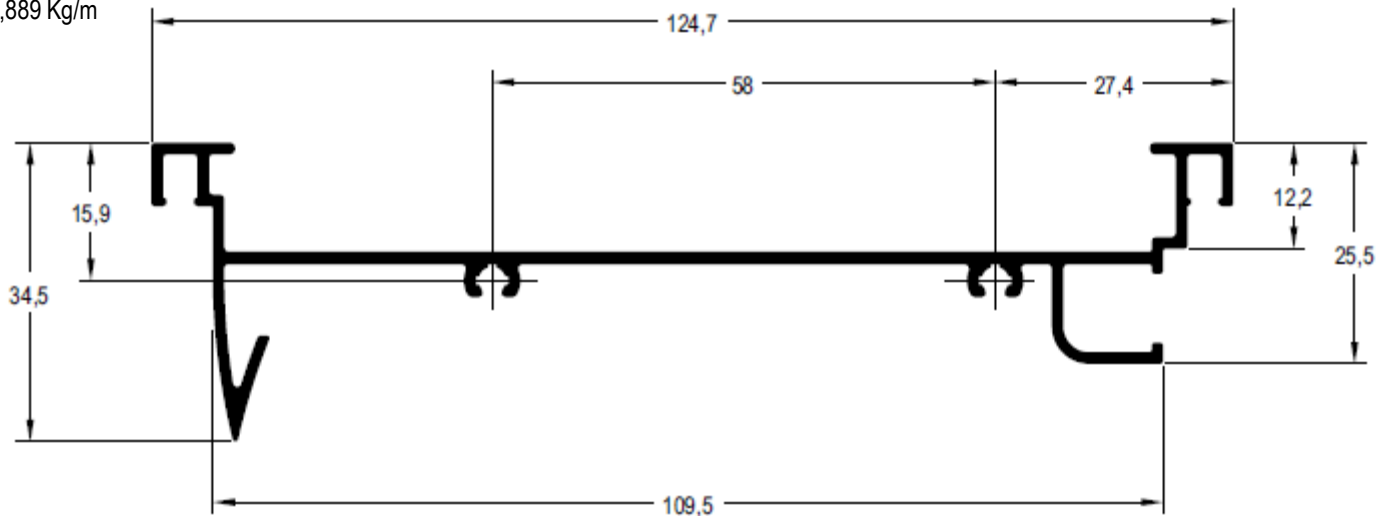

SPI – M59

Travessa intermediária da caixa
0,656 Kg/m

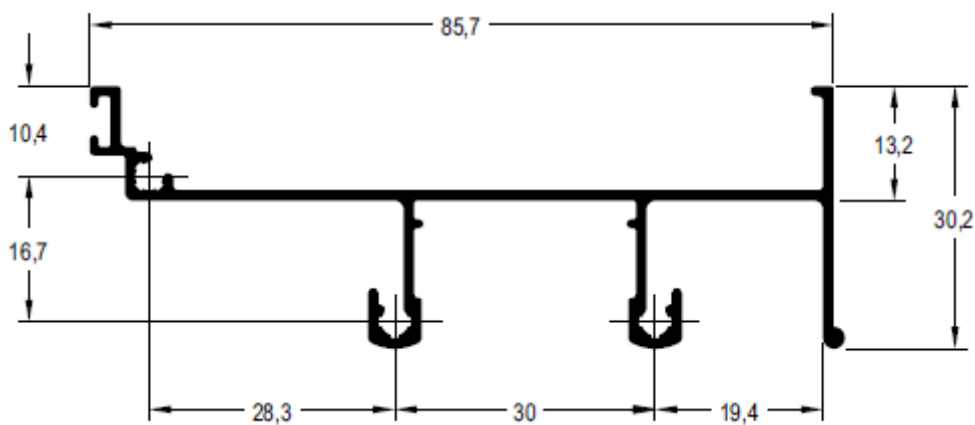

SPI – M57

Marco inferior
0,980 Kg/m

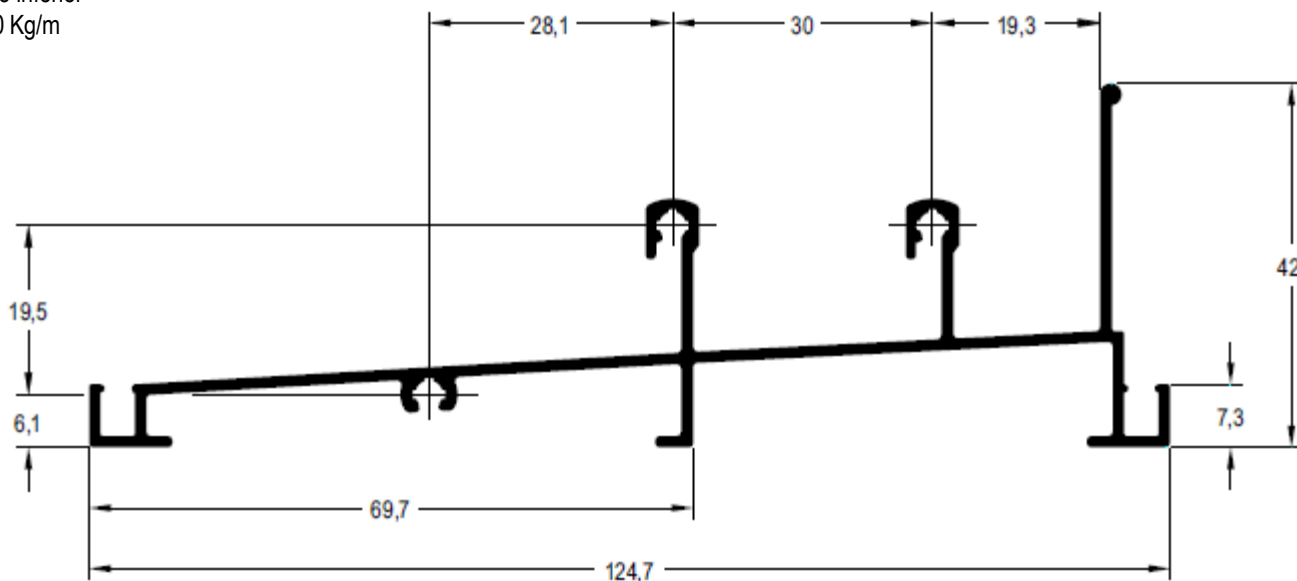

SPI – M16

Tampa externa
0,698 Kg/m

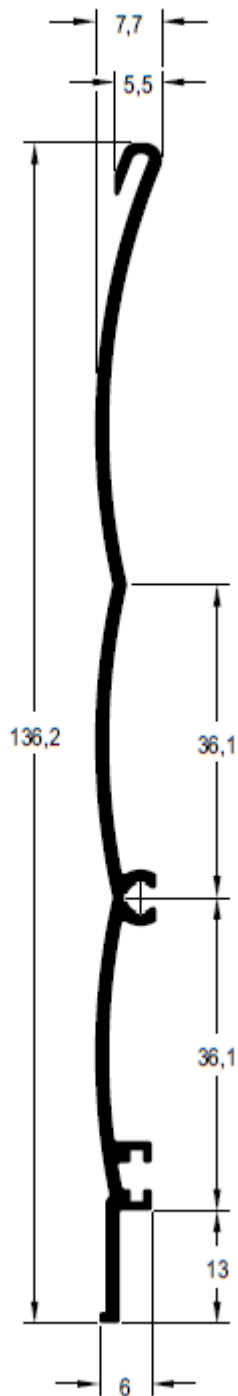

SPI – M99

Tampa externa
0,765 Kg/m

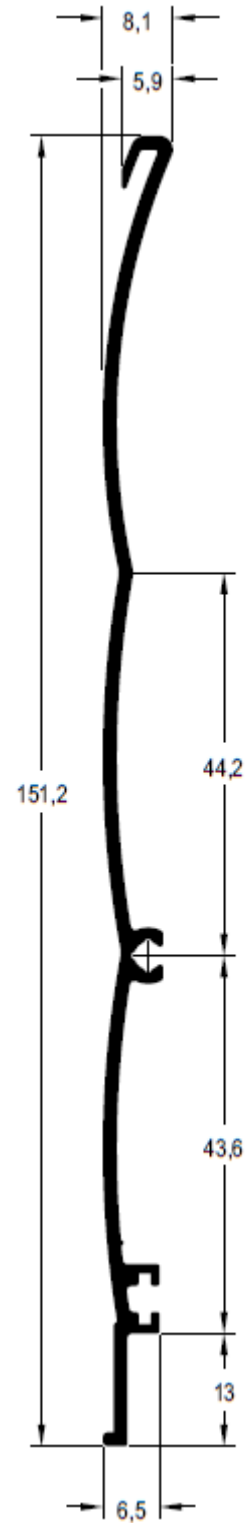

SPI – M56

Guia lateral
0,960 Kg/m

SPI – M60

Marco lateral
0,599 Kg/m

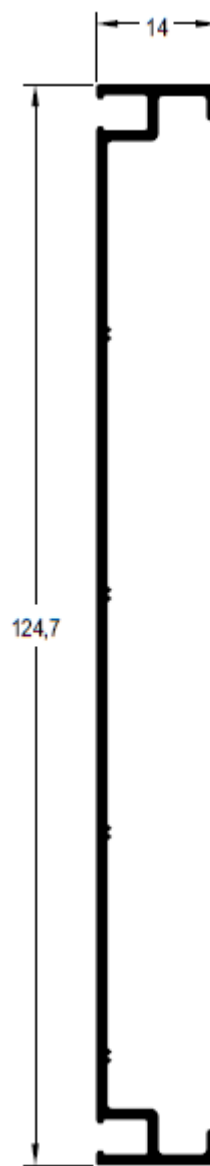
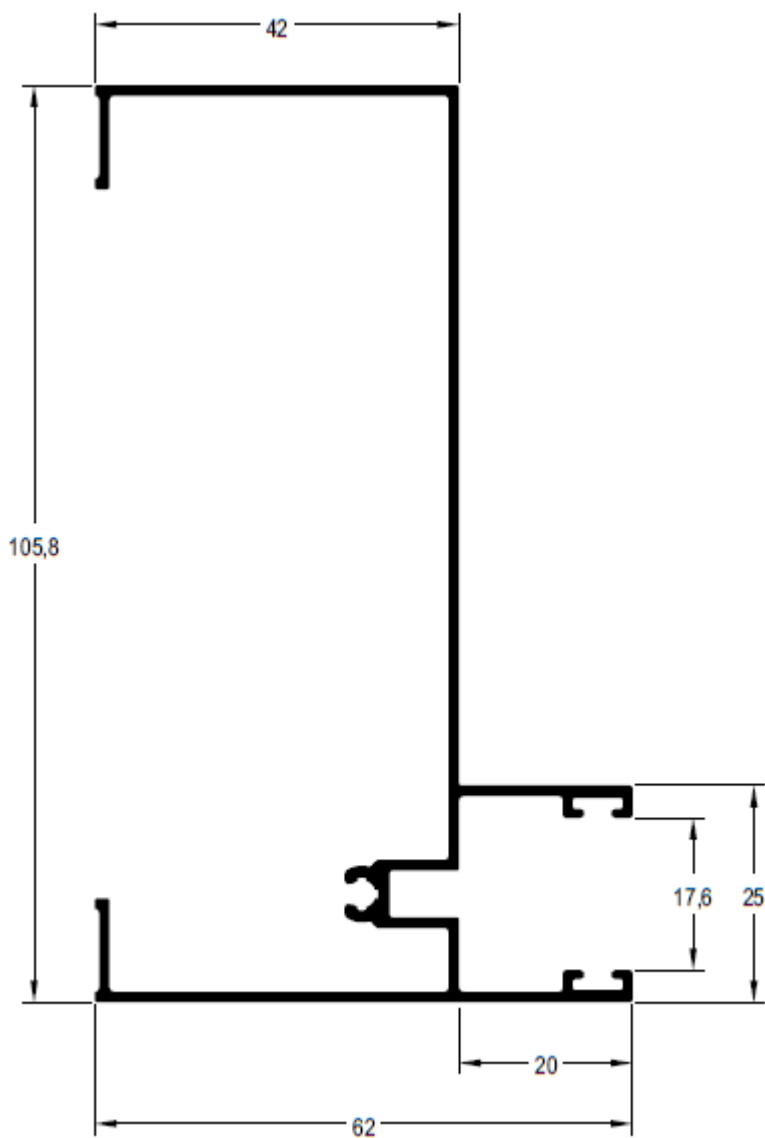

SPI – M63

Tampa externa
0,495 Kg/m

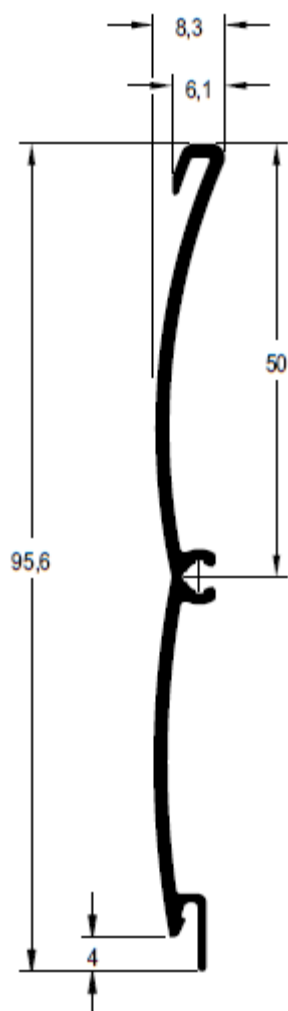

SPI – M64

Tampa externa
0,558 Kg/m

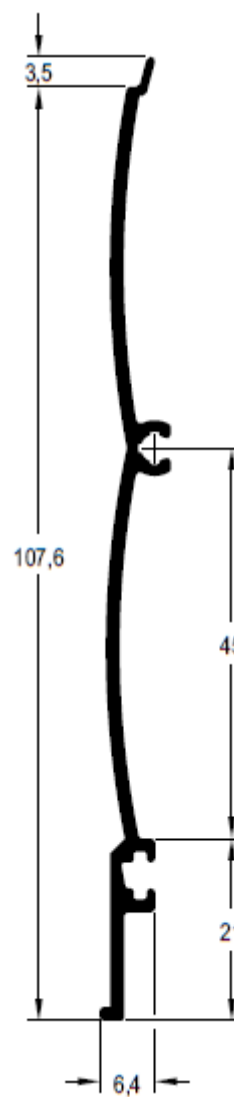

SPI – M13

Guia lateral
1,267 Kg/m

SPI – M12

Guia lateral
1,267 Kg/m

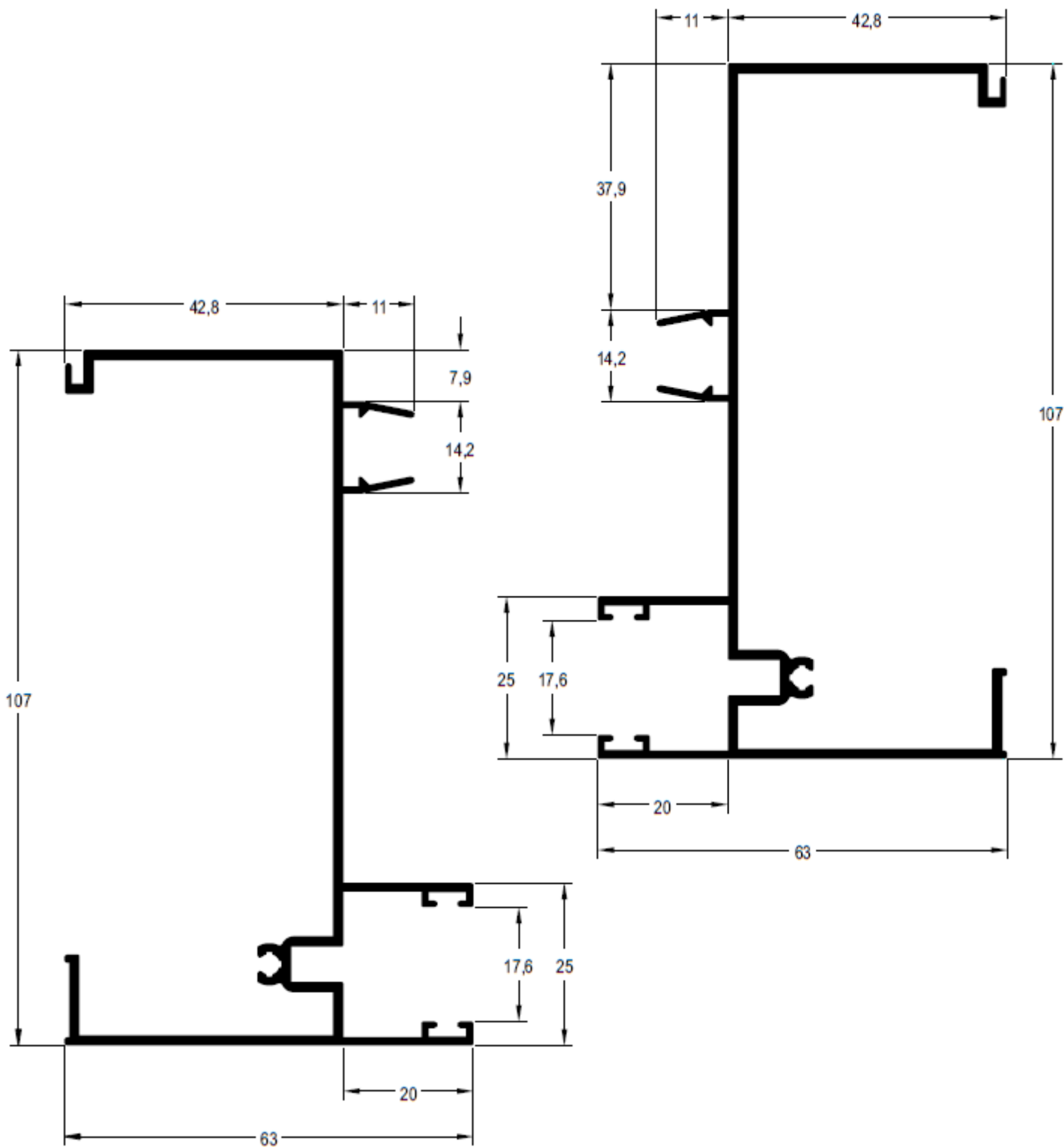

SPI - 104

Guia lateral
0,687 Kg/m

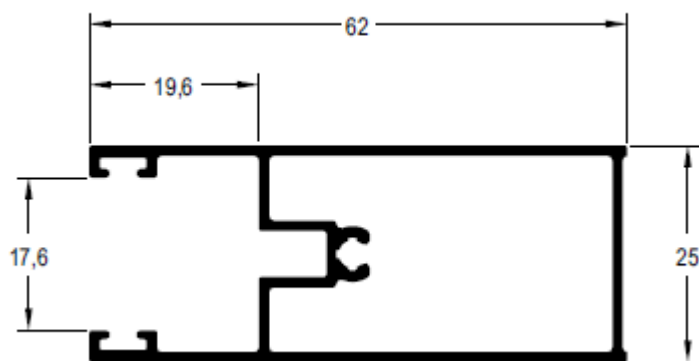

DS - 238

Arremate
0,521 Kg/m

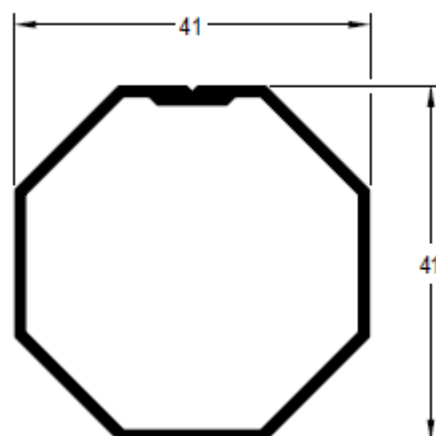

MN - 055

Terminal da persiana
0,371 Kg/m

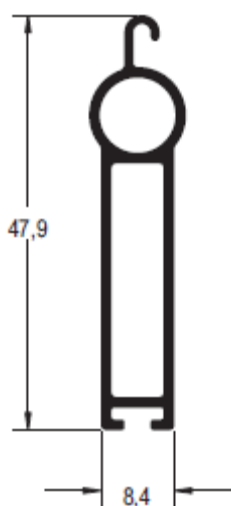

MN - 015

Tubo recolhedor
0,881 Kg/m

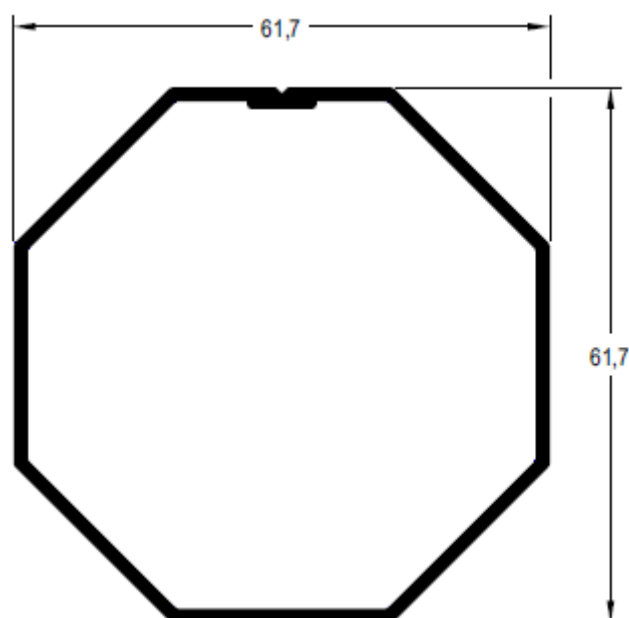

TIPOLOGIAS

JANELAS DE CORRER

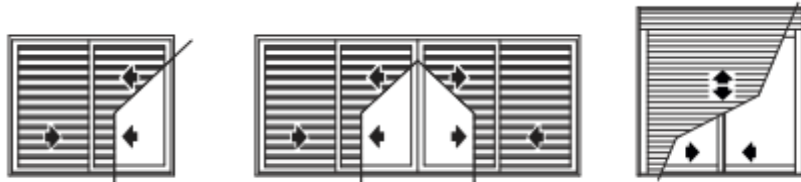
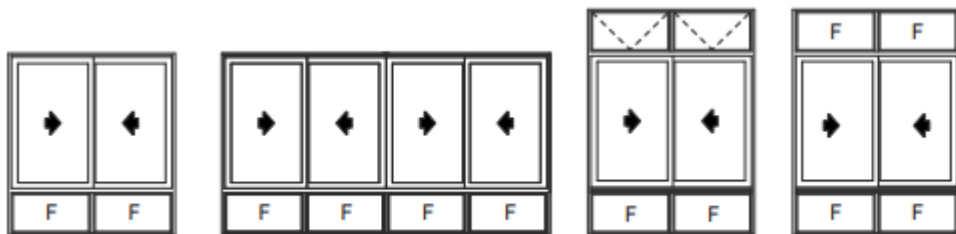
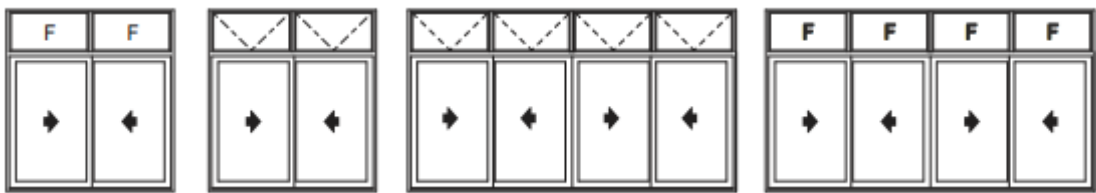

PORTAS DE CORRER

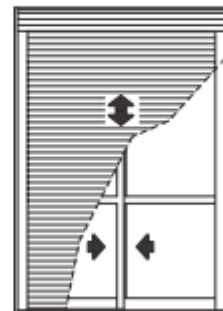
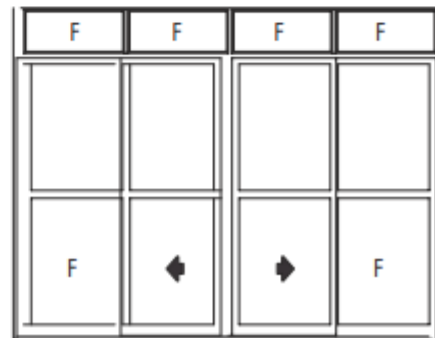
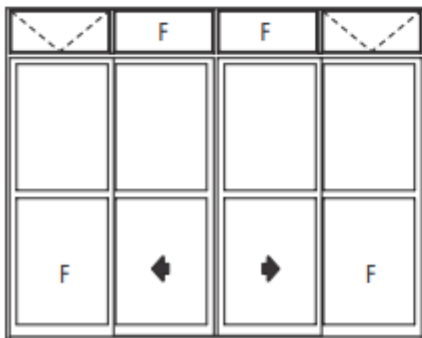
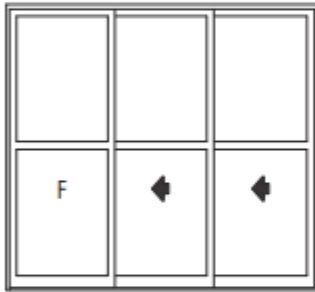
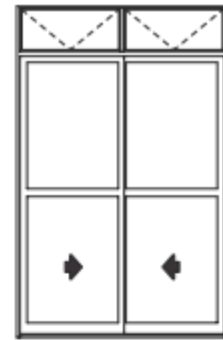
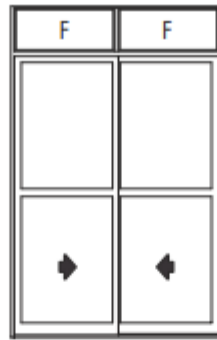
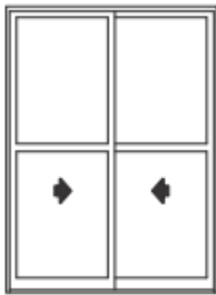

TIPOLOGIAS

MAXIM-AR



DIAGRAMA DE DIMENSÕES

PORTA DE CORRER DE 3 FOLHAS



20SP-F08	20SP-F04	20SP-F08
$J_x = 23,668 \text{ cm}^4$	$J_x = 2,144 \text{ cm}^4$	$J_x = 23,668 \text{ cm}^4$
$J_y = 5,670 \text{ cm}^4$	$J_y = 1,832 \text{ cm}^4$	$J_y = 5,670 \text{ cm}^4$
$W_x = 6,286 \text{ cm}^3$	$W_x = 1,268 \text{ cm}^3$	$W_x = 6,286 \text{ cm}^3$
$W_y = 2,967 \text{ cm}^3$	$W_y = 0,893 \text{ cm}^3$	$W_y = 2,967 \text{ cm}^3$
$J_x \text{ Total} = 49,480 \text{ cm}^4$		

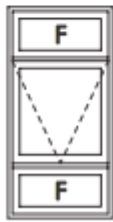
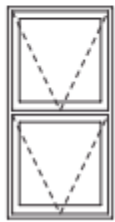
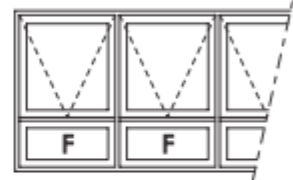
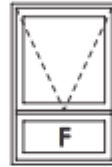
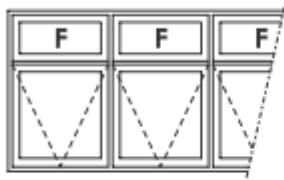
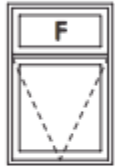
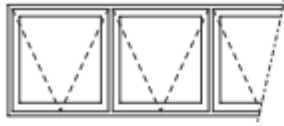
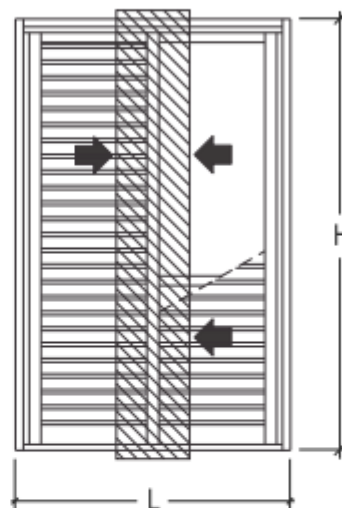
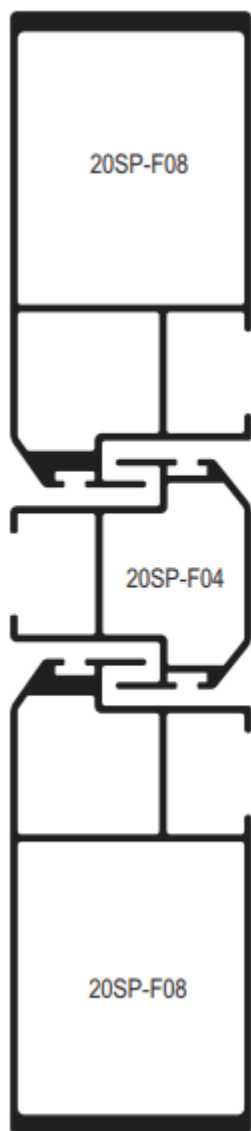

DIAGRAMA DE DIMENSÕES

JANELA DE CORRER DE 2 FOLHAS



20SPA-F103	20SPA-F103
$Jx = 1,375 \text{ cm}^4$	$Jx = 1,375 \text{ cm}^4$
$Jy = 1,720 \text{ cm}^4$	$Jy = 1,720 \text{ cm}^4$
$Wx = 0,973 \text{ cm}^3$	$Wx = 0,973 \text{ cm}^3$
$Wy = 0,867 \text{ cm}^3$	$Wy = 0,867 \text{ cm}^3$
$Jx \text{ Total} = 2,750 \text{ cm}^4$	

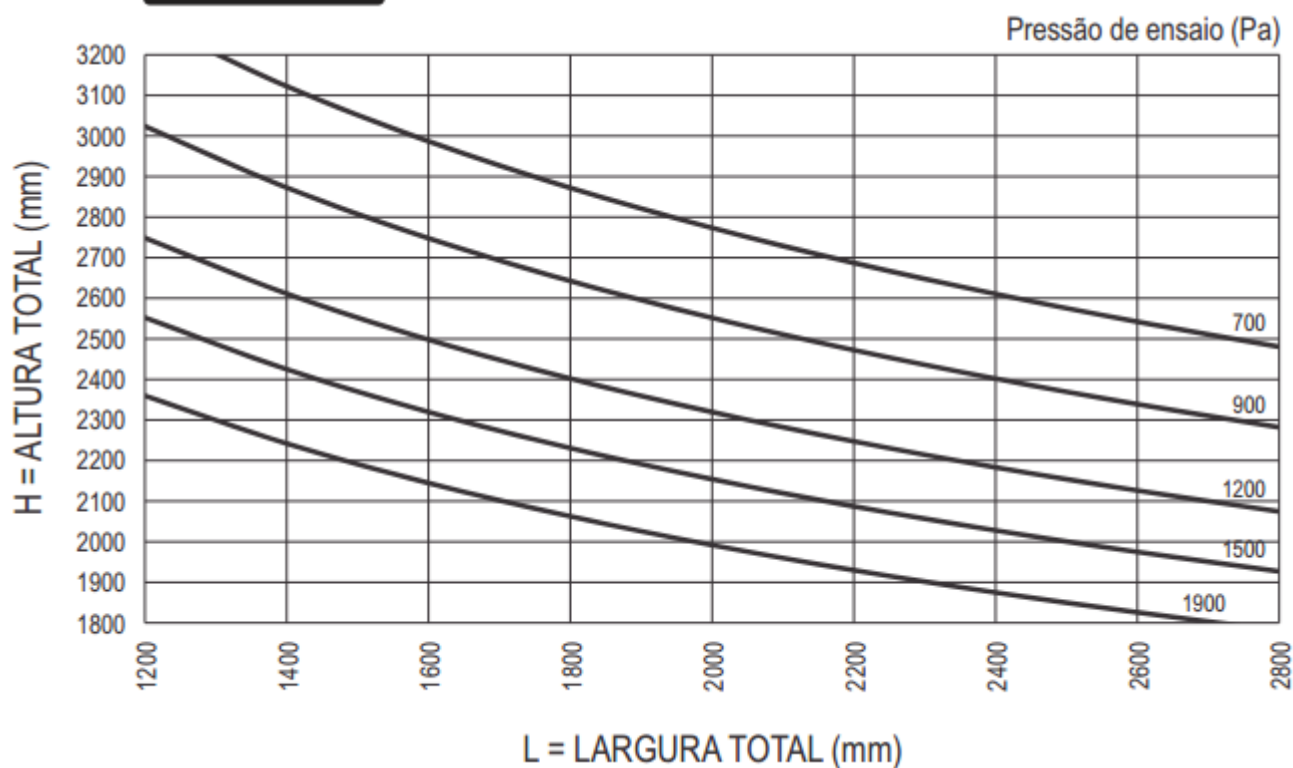
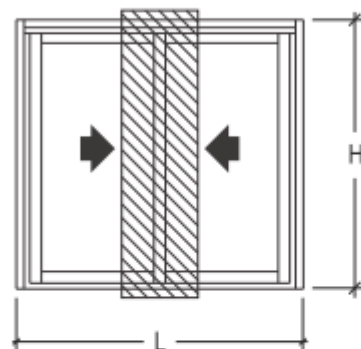
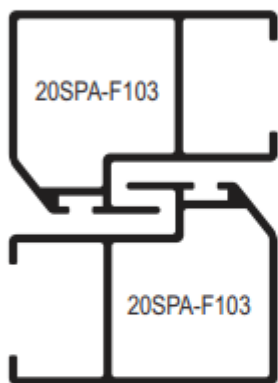

DIAGRAMA DE DIMENSÕES

PORTA DE CORRER DE 2 FOLHAS



20SP-F07	20SP-F08
$J_x = 3,880 \text{ cm}^4$	$J_x = 23,668 \text{ cm}^4$
$J_y = 2,965 \text{ cm}^4$	$J_y = 5,670 \text{ cm}^4$
$W_x = 1,826 \text{ cm}^3$	$W_x = 6,286 \text{ cm}^3$
$W_y = 1,546 \text{ cm}^3$	$W_y = 2,967 \text{ cm}^3$
$J_x \text{ Total} = 27,548 \text{ cm}^4$	

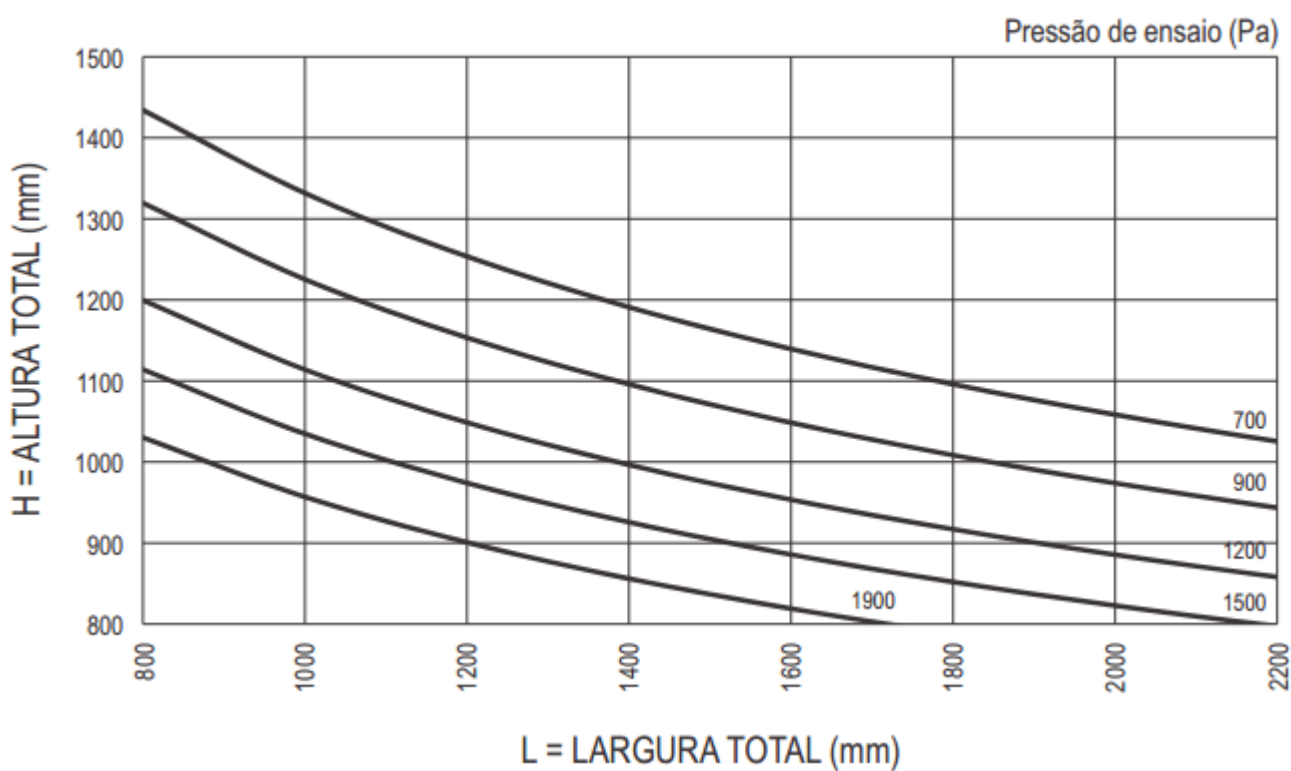
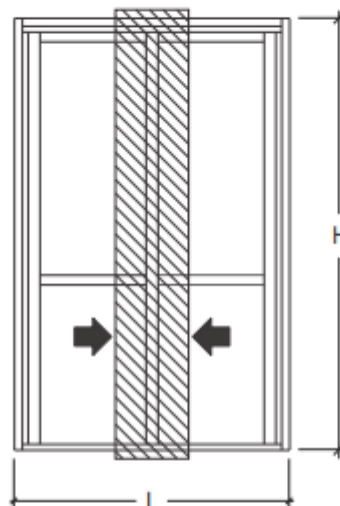
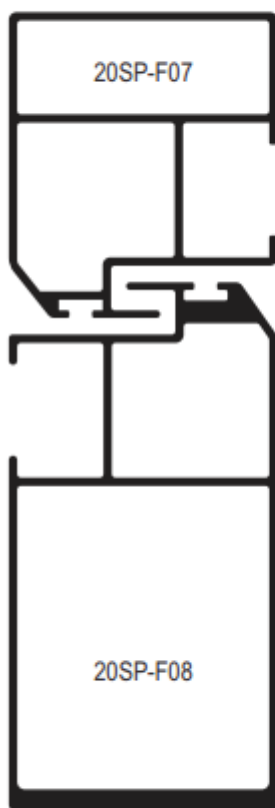

DIAGRAMA DE DIMENSÕES

PORTA DE CORRER DE 2 FOLHAS



20SP-F08	20SP-F08
$Jx = 23,668 \text{ cm}^4$	$Jx = 23,668 \text{ cm}^4$
$Jy = 5,670 \text{ cm}^4$	$Jy = 5,670 \text{ cm}^4$
$Wx = 6,286 \text{ cm}^3$	$Wx = 6,286 \text{ cm}^3$
$Wy = 2,967 \text{ cm}^3$	$Wy = 2,967 \text{ cm}^3$
$Jx \text{ Total} = 47,336 \text{ cm}^4$	

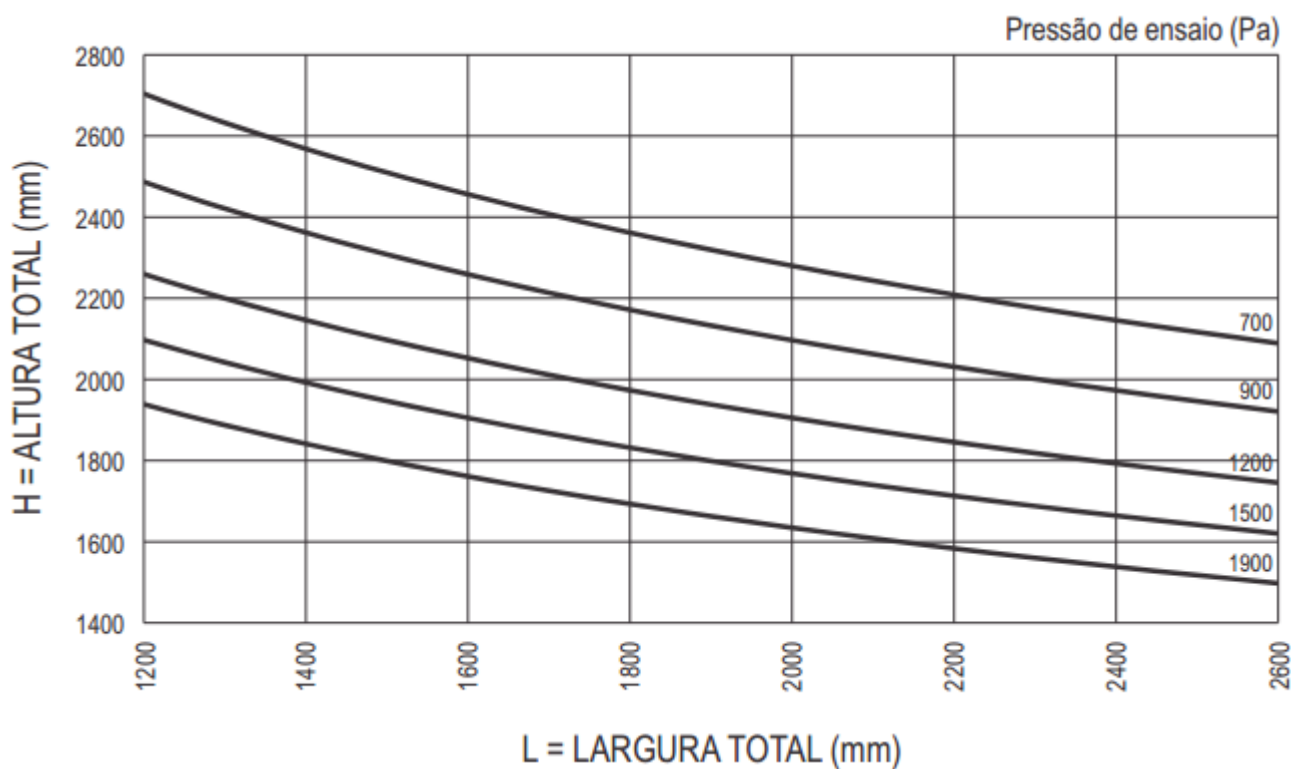
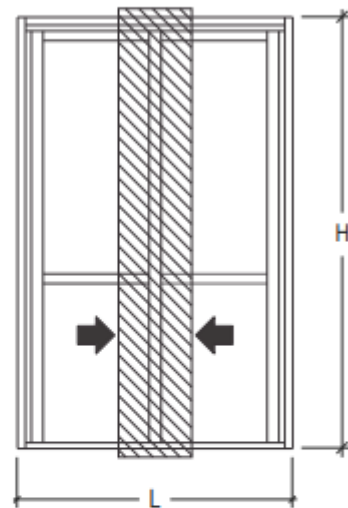
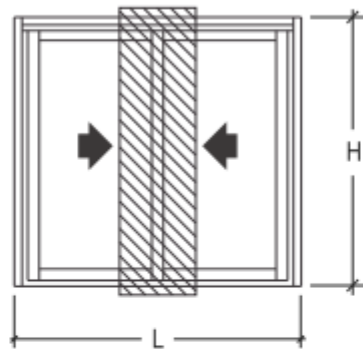
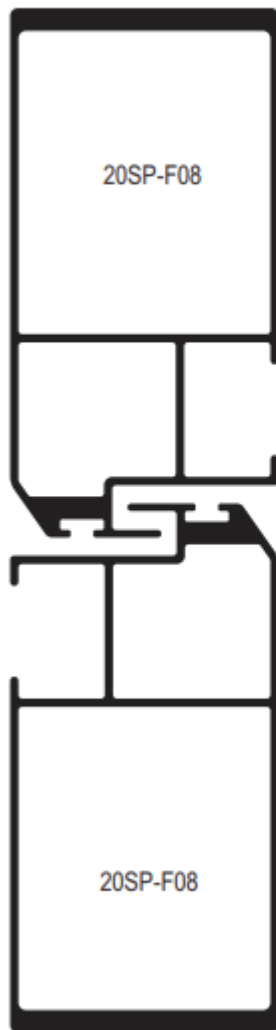

DIAGRAMA DE DIMENSÕES

JANELA DE CORRER DE 2 FOLHAS



20SPA-F103	20SPA-F107
$J_x = 1,375 \text{ cm}^4$	$J_x = 3,880 \text{ cm}^4$
$J_y = 1,720 \text{ cm}^4$	$J_y = 2,965 \text{ cm}^4$
$W_x = 0,973 \text{ cm}^3$	$W_x = 1,826 \text{ cm}^3$
$W_y = 0,867 \text{ cm}^3$	$W_y = 1,546 \text{ cm}^3$
$J_x \text{ Total} = 5,255 \text{ cm}^4$	

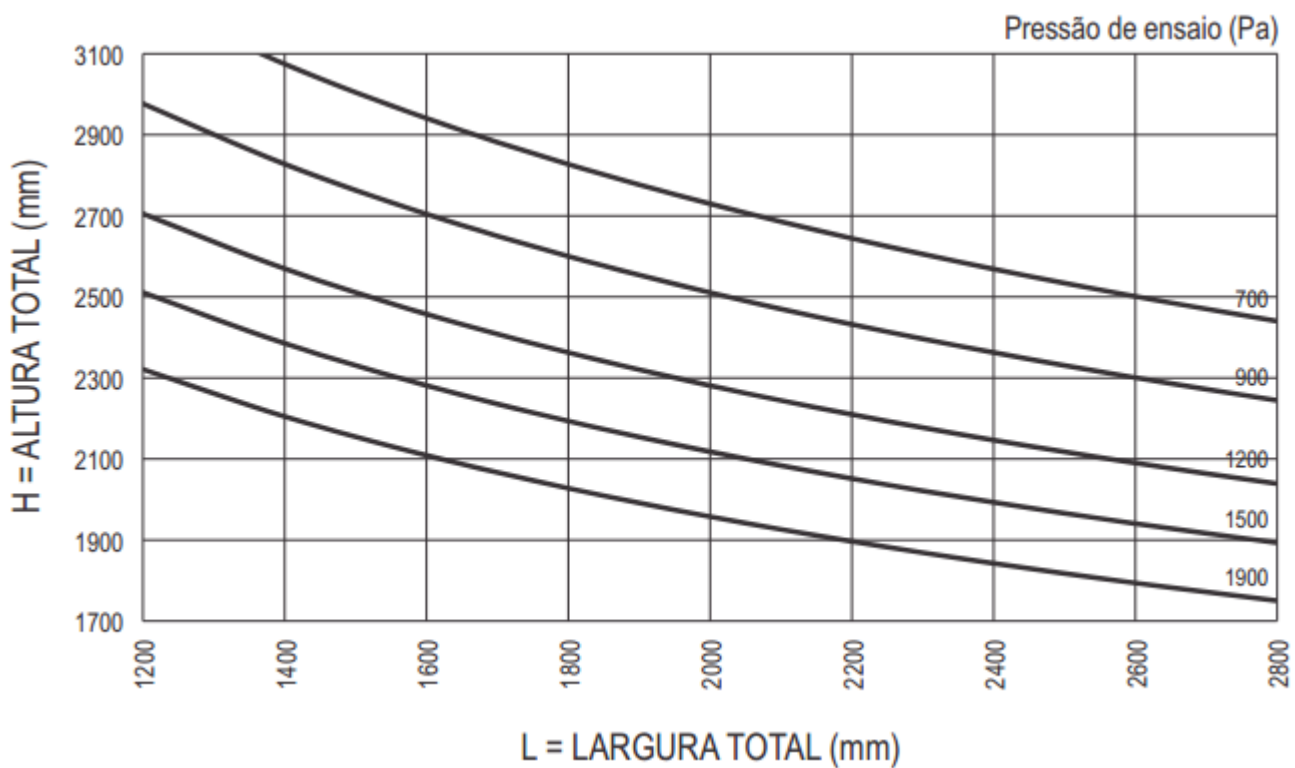
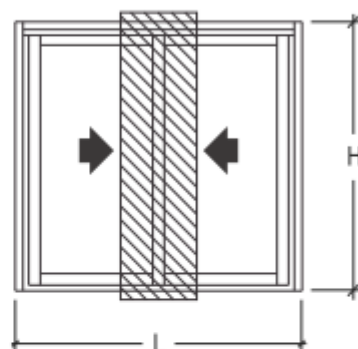
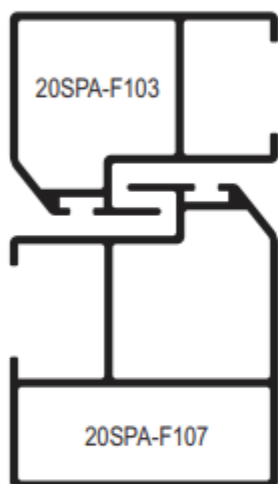

DIAGRAMA DE DIMENSÕES

JANELA DE CORRER DE 2 FOLHAS

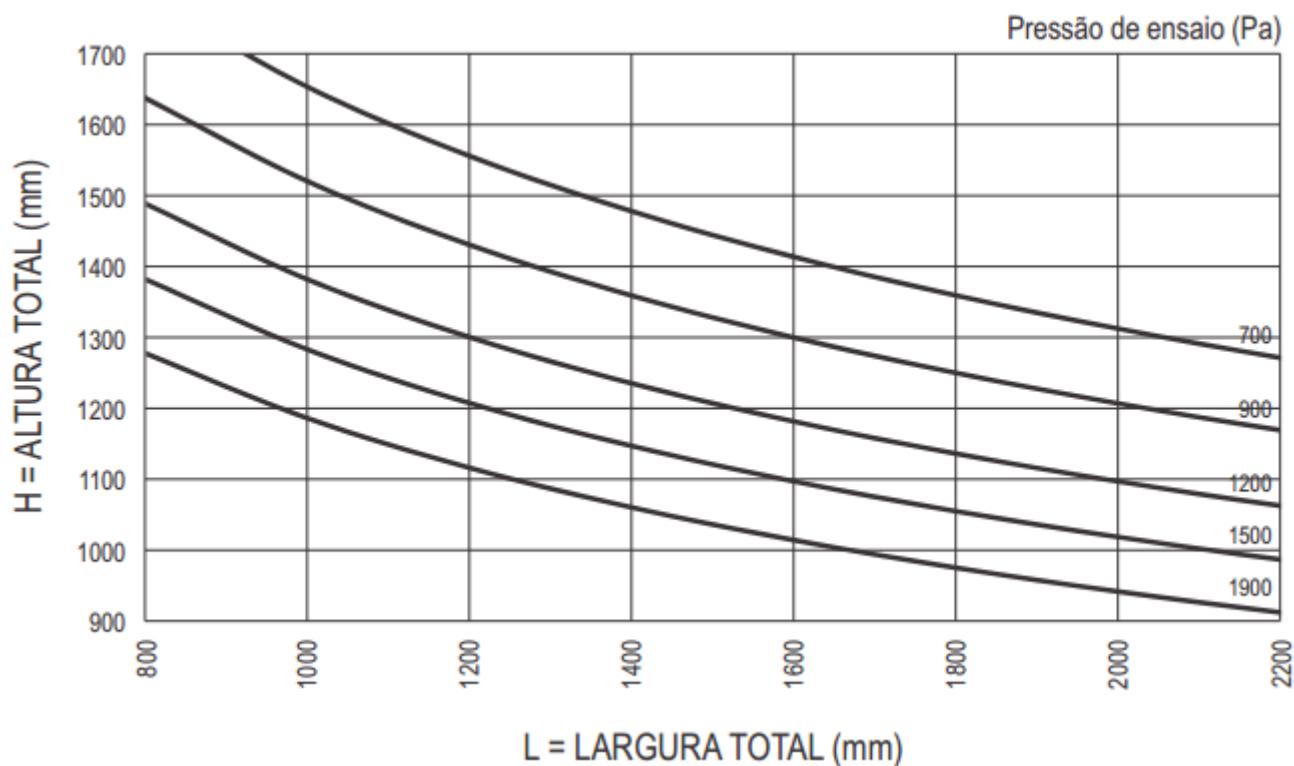
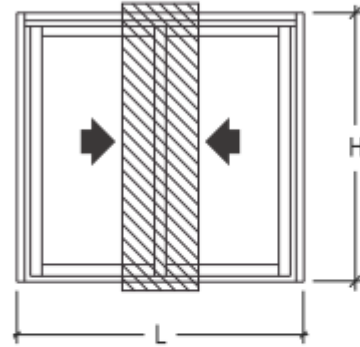
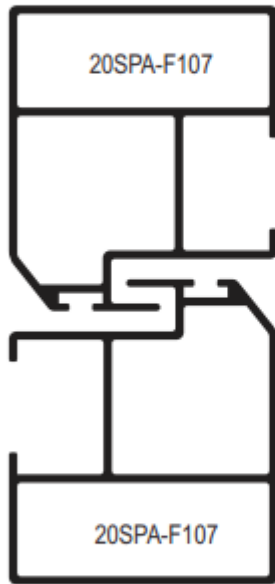

20SPA-F107

$J_x = 3,880 \text{ cm}^4$
 $J_y = 2,965 \text{ cm}^4$
 $W_x = 1,826 \text{ cm}^3$
 $W_y = 1,546 \text{ cm}^3$

20SPA-F107

$J_x = 3,880 \text{ cm}^4$
 $J_y = 2,965 \text{ cm}^4$
 $W_x = 1,826 \text{ cm}^3$
 $W_y = 1,546 \text{ cm}^3$

$J_x \text{ Total} = 7,760 \text{ cm}^4$



DIAGRAMA DE DIMENSÕES

PORTA/JANELA DE CORRER DE 2 FOLHAS



20SP-F03	20SP-F08
$J_x = 1,375 \text{ cm}^4$	$J_x = 23,668 \text{ cm}^4$
$J_y = 1,720 \text{ cm}^4$	$J_y = 5,670 \text{ cm}^4$
$W_x = 0,973 \text{ cm}^3$	$W_x = 6,286 \text{ cm}^3$
$W_y = 0,867 \text{ cm}^3$	$W_y = 2,967 \text{ cm}^3$
$J_x \text{ Total} = 25,043 \text{ cm}^4$	

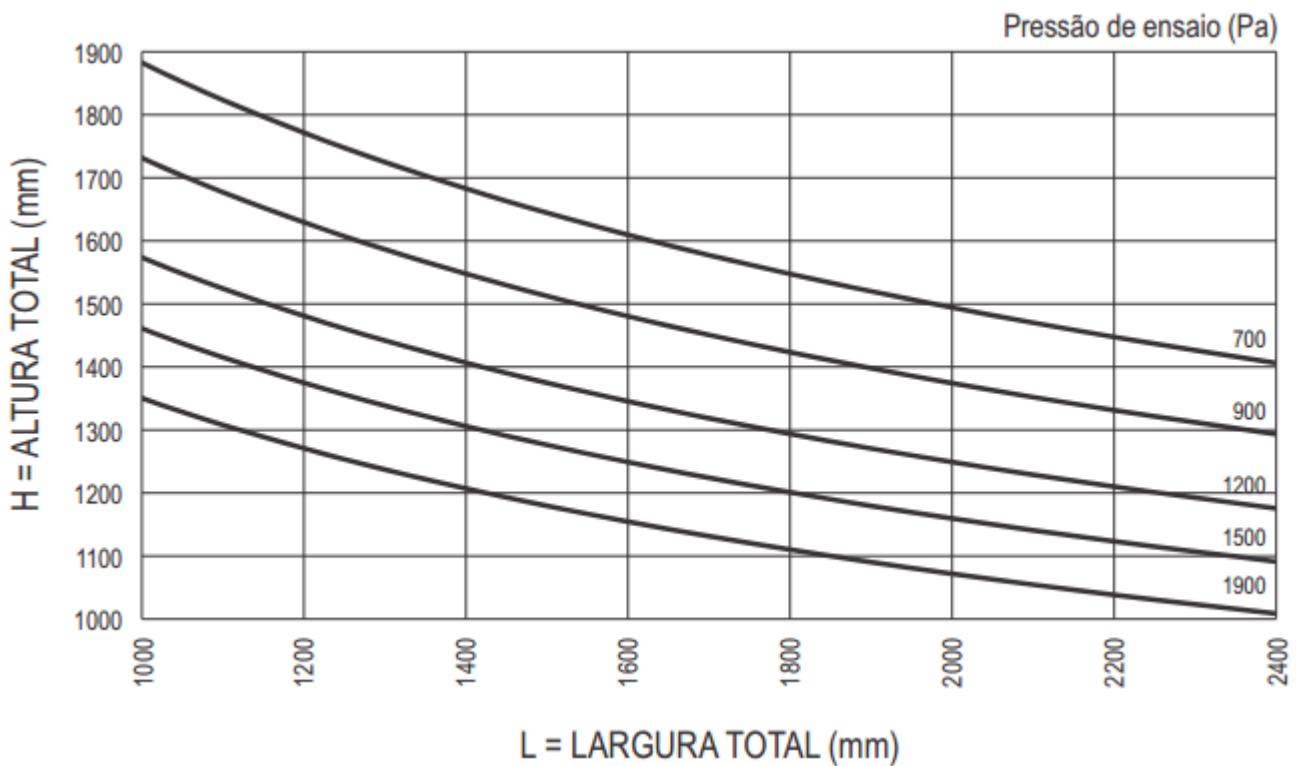
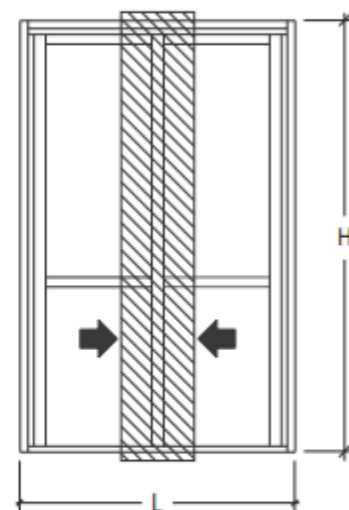
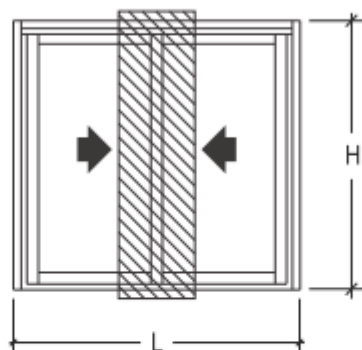
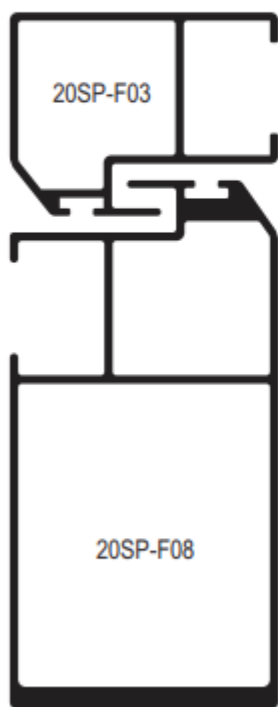

DIAGRAMA DE DIMENSÕES

PORTA DE CORRER DE 3 FOLHAS



20SP-F07	20SP-F04	20SP-F08
Jx = 3,880 cm ⁴	Jx = 2,144 cm ⁴	Jx = 23,668 cm ⁴
Jy = 2,965 cm ⁴	Jy = 1,832 cm ⁴	Jy = 5,670 cm ⁴
Wx = 1,826 cm ³	Wx = 1,268 cm ³	Wx = 6,286 cm ³
Wy = 1,546 cm ³	Wy = 0,893 cm ³	Wy = 2,967 cm ³
Jx Total = 29,692 cm ⁴		

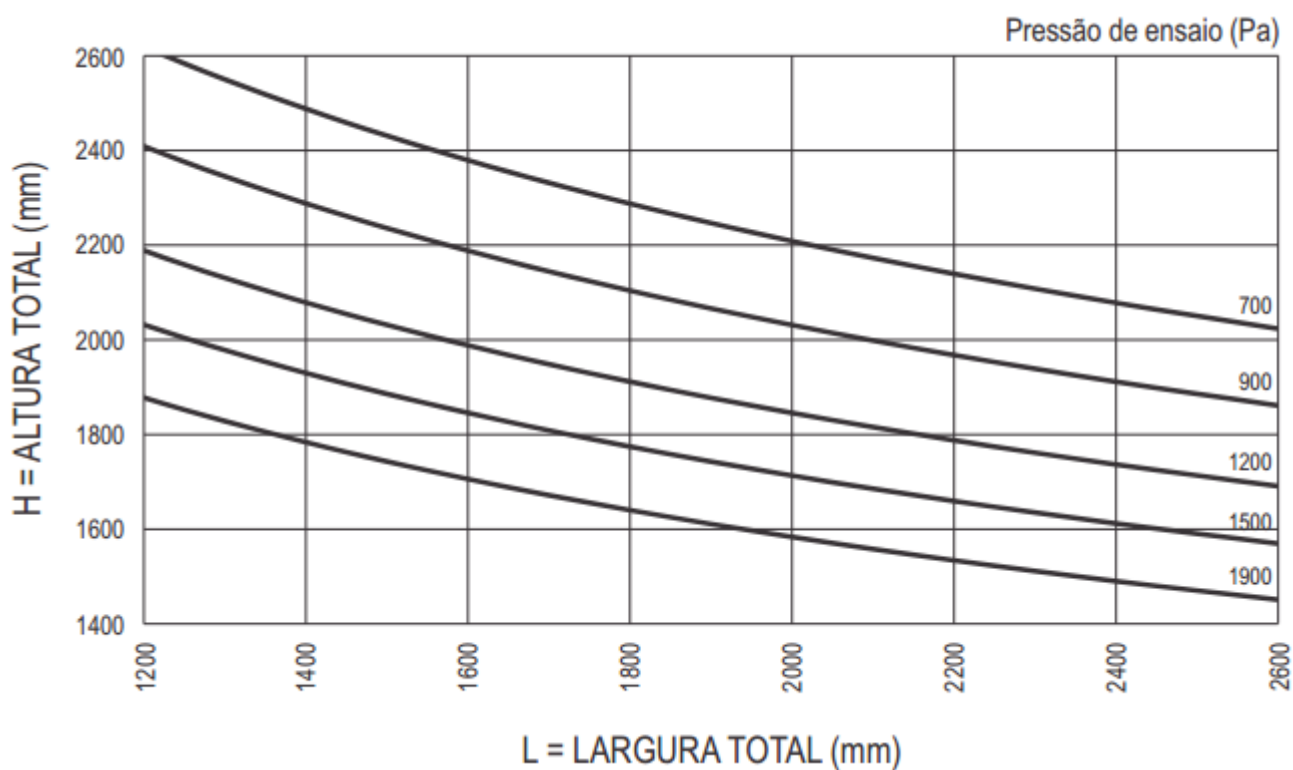
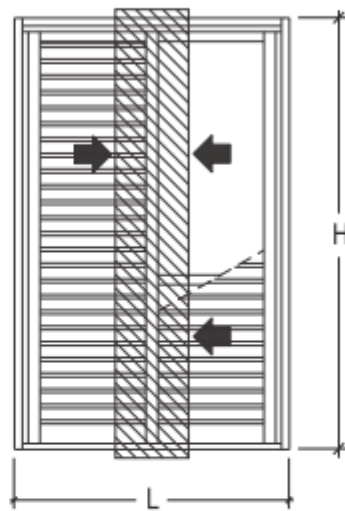
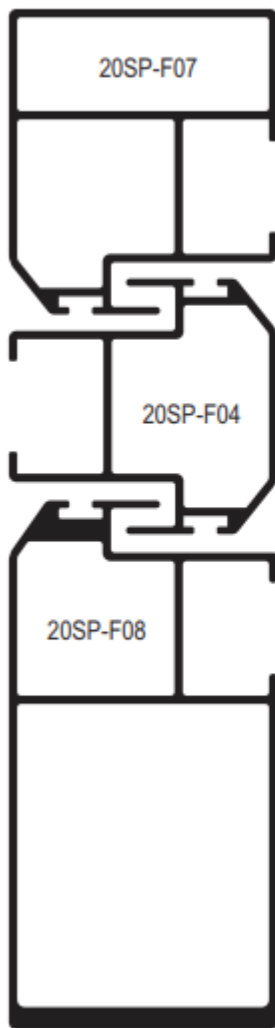

DIAGRAMA DE DIMENSÕES

JANELA DE CORRER DE 4FOLHAS



20SP-F01	20SP-F02
$J_x = 1,127 \text{ cm}^4$	$J_x = 1,007 \text{ cm}^4$
$J_y = 2,959 \text{ cm}^4$	$J_y = 3,233 \text{ cm}^4$
$W_x = 1,067 \text{ cm}^3$	$W_x = 1,007 \text{ cm}^3$
$W_y = 1,251 \text{ cm}^3$	$W_y = 1,266 \text{ cm}^3$
$J_x \text{ Total} = 2,134 \text{ cm}^4$	

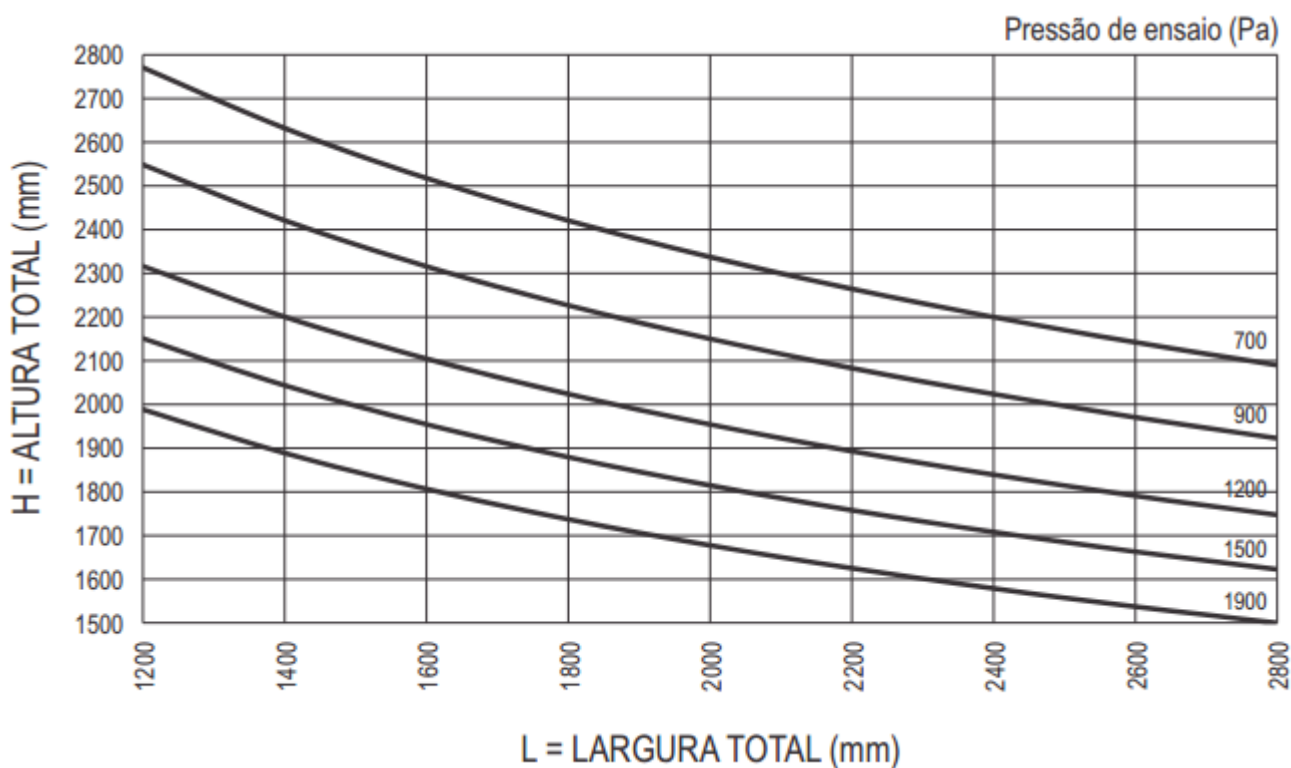
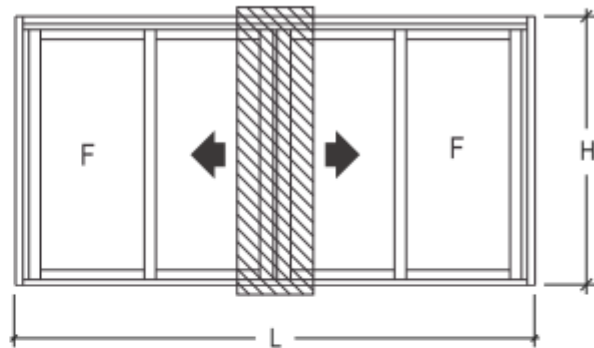

DIAGRAMA DE DIMENSÕES

PORTA DE CORRER DE 4 FOLHAS



20SP-F11	20SP-F12
$J_x = 12,494 \text{ cm}^4$	$J_x = 12,830 \text{ cm}^4$
$J_y = 6,182 \text{ cm}^4$	$J_y = 6,553 \text{ cm}^4$
$W_x = 4,199 \text{ cm}^3$	$W_x = 4,219 \text{ cm}^3$
$W_y = 2,363 \text{ cm}^3$	$W_y = 2,286 \text{ cm}^3$
$J_x \text{ Total} = 25,324 \text{ cm}^4$	

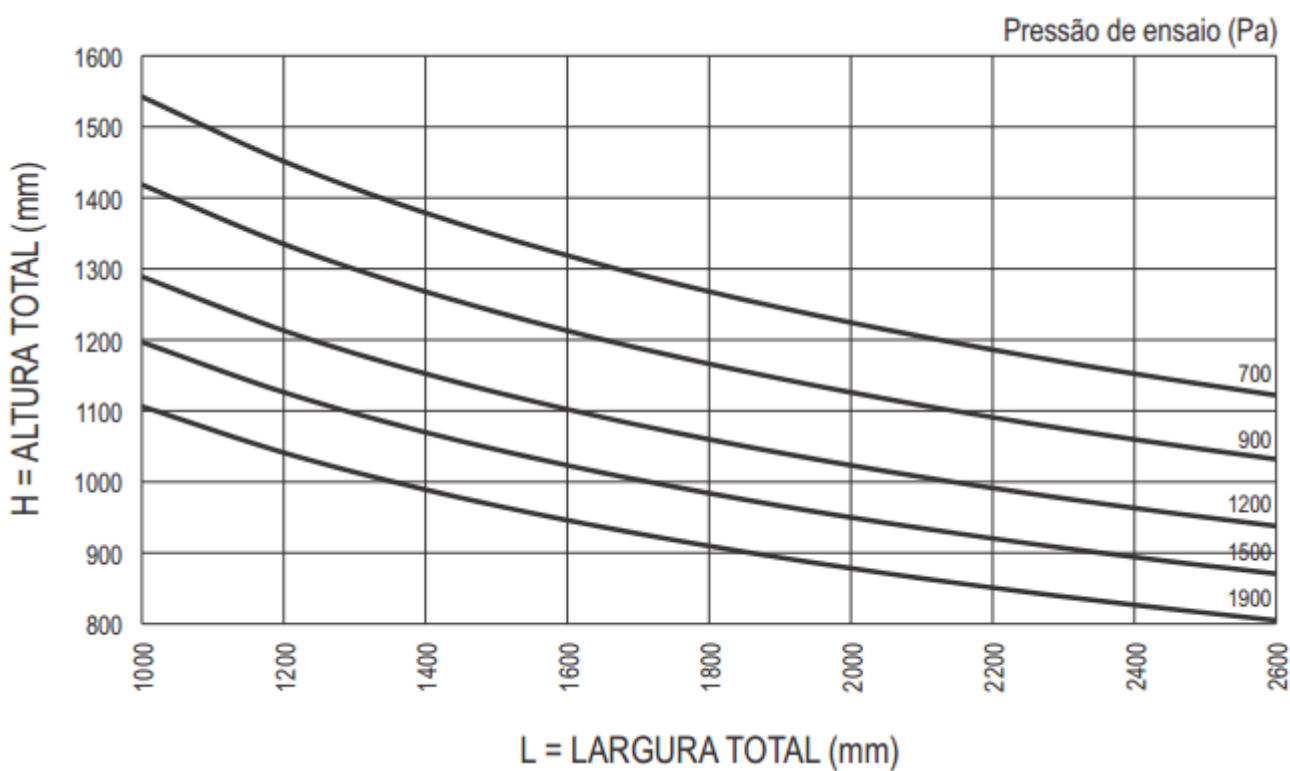
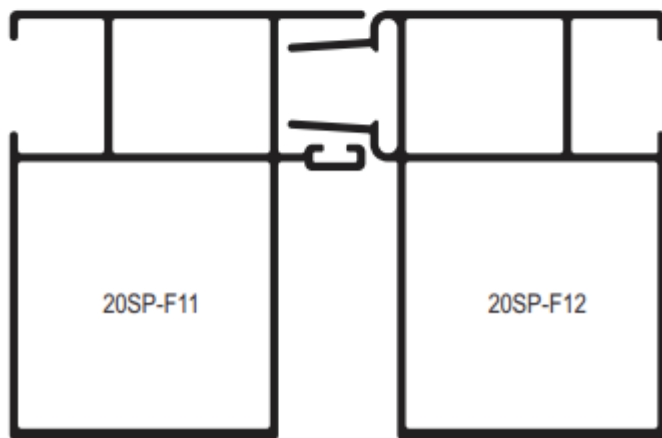
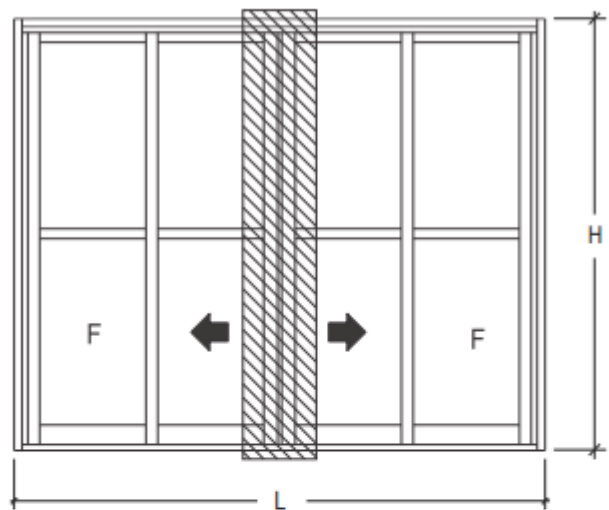

DIAGRAMA DE DIMENSÕES

JANELA DE CORRER DE 3 FOLHAS



20SP-F07	20SP-F04	20SP-F07
Jx = 3,880 cm ⁴	Jx = 2,144 cm ⁴	Jx = 3,880 cm ⁴
Jy = 2,965 cm ⁴	Jy = 1,832 cm ⁴	Jy = 2,965 cm ⁴
Wx = 1,826 cm ³	Wx = 1,268 cm ³	Wx = 1,826 cm ³
Wy = 1,546 cm ³	Wy = 0,893 cm ³	Wy = 1,546 cm ³
Jx Total = 9,904 cm ⁴		

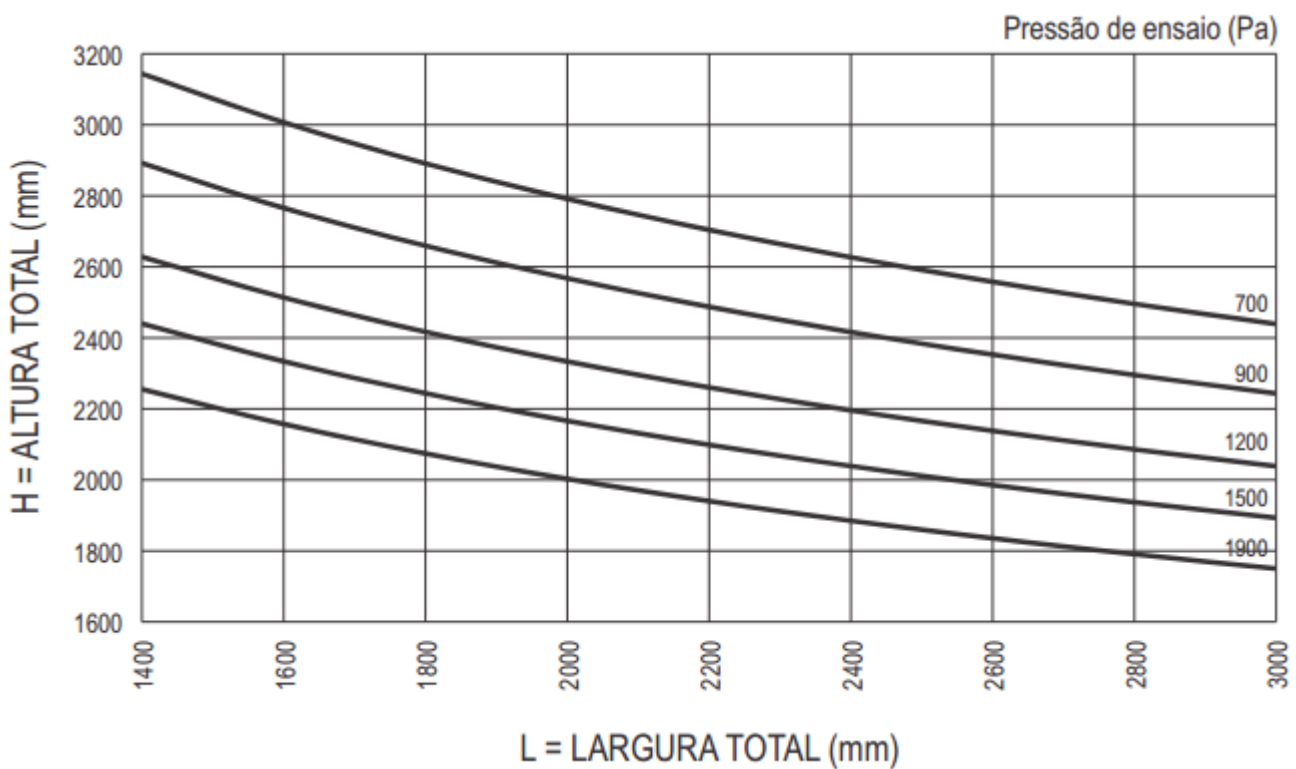
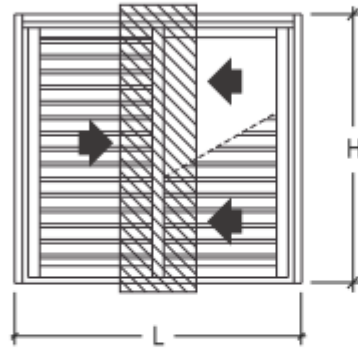
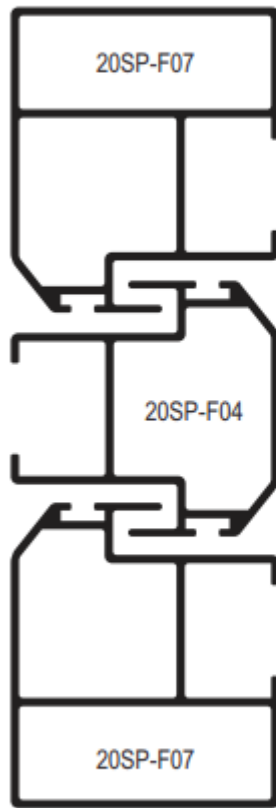





DIAGRAMA DE DIMENSÕES

JANELA DE CORRER DE 2 FOLHAS

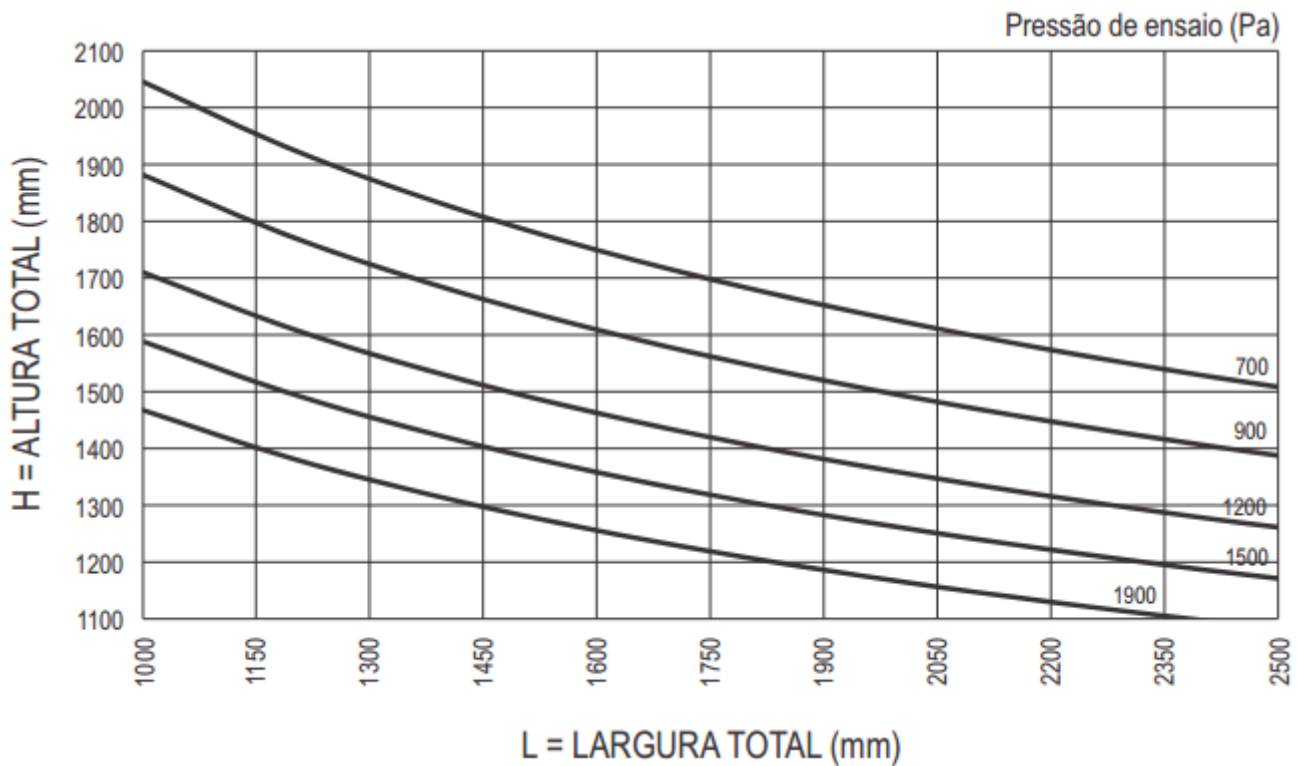
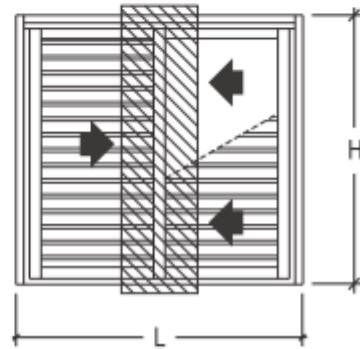
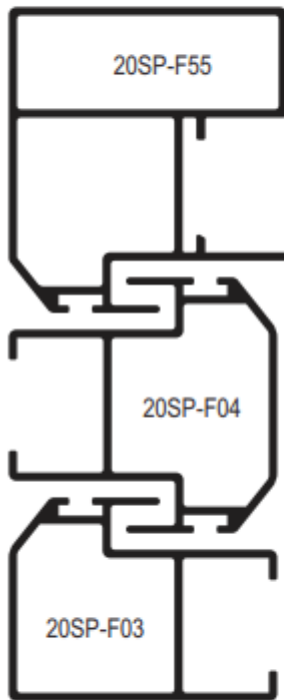
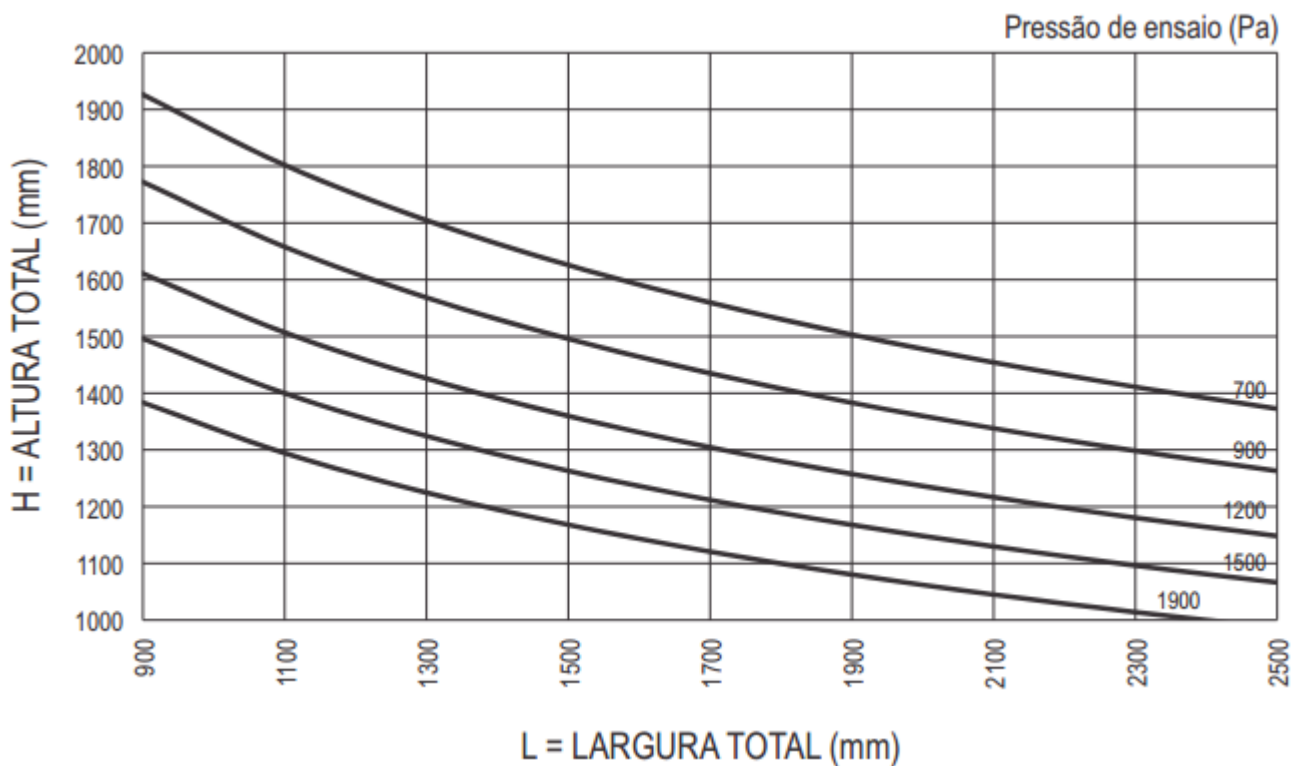

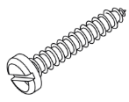
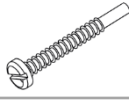
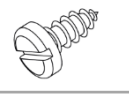
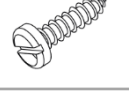
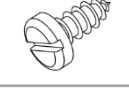
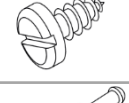
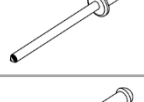
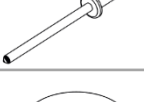
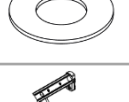
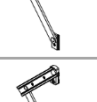
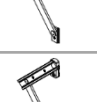
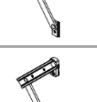
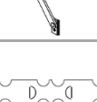



20SP-F55	20SP-F04	20SP-F03
Jx = 3,962 cm ⁴	Jx = 2,144 cm ⁴	Jx = 1,375 cm ⁴
Jy = 3,041 cm ⁴	Jy = 1,832 cm ⁴	Jy = 1,720 cm ⁴
Wx = 1,858 cm ³	Wx = 1,268 cm ³	Wx = 0,973 cm ³
Wy = 1,498 cm ³	Wy = 0,893 cm ³	Wy = 0,867 cm ³
Jx Total = 7,481 cm ⁴		



ACESSÓRIO	CÓDIGO	CÓDIGO UNIVERSAL	DESCRIÇÃO
	PAR-215	PARFZAPF03916	Parafuso A.A. cabeça panela 3,9 x 25 AZ
	PAR-428	PARFIPPF04832	Parafuso cabeça panela P.P. 4,8 x 32
	PAR-434	PARFIAPF04295	Parafuso auto atarrachante 3,9 x 9,5
	PAR-691	PARFIAPF04813	Parafuso auto atarrachante cabeça panela 4,8 x 13
	PAR-703	PARFIAPF03595	Parafuso auto atarrachante cabeça panela 3,5 x 9,5
	PAR-704	PARFIAPF03965	Parafuso auto atarrachante cabeça panela 3,5 x 6,5
	REB-115	REBTAPE40102	Rebite POP al. 4,0 x 10,2
	REB-117	REBTAPE32102	Rebite POP al. 3,2 x 10,2
	ARR-569	ARRU00569	Arruela Lisa 4,3 x 9 Aço Inox
	BRA-705	BRAC00705	Braço max com 250 mm
	BRA-702	BRAC00702	Braço max com 500 mm
	BRA-703	BRAC00703	Braço com 750 mm
	BRA-725	BRAC00725	Braço com 810 mm
	CHU-787	CHUM00787	Chumbador aço zincado
	CHU-840	CHUM00857	Chumbador alumínio
	FEC-280	CONC00280	Concha alumínio sem Trava

ACESSÓRIO	CÓDIGO	CÓDIGO UNIVERSAL	DESCRIÇÃO
	FEC-370	CONF00370	Contra fecho lateral
	F-07	TAMP10027	Tampa do perfil 20SP-F07 / 20SP-F06
	F-08	TAMP10028	Tampa do perfil 20SP-F08
	FEC-059	HAST00059	Haste de comando janela projetante
	FEC-645	FECH00645	Fecho concha com chave com trava reta
	FEC-636	FECH00636	Fecho concha com trava reta
	FIT-214	FITA050X100	Fita de vedação PB-481000 3P
	PRE-04	FITAD012X012	Presilha de fixação da esteira
	FEC-063	FECH10023D	Fecho frontal mini 95 mm – Maxim-ar
	GUA-157	GUAR00157	Guarnição adesiva vidro 6 X 11 mm
	GUA-171	GUAR00171	Guarnição esponja adesiva 3 X 11,2 mm
	GUA-256	GUAR00256	Guarnição EPDM cunha
	GUA-007	GUAR00007	Guarnição pingadeira 11 mm EPDM
	GUA-228	GUAR00228	Guarnição adesiva veneziana
	GUA-284	GUAR00284	Guarnição EPDM 4 mm
	GUA-290	GUAR00290	Guarnição externa EPDM

ACESSÓRIO	CÓDIGO	CÓDIGO UNIVERSAL	DESCRIÇÃO
	NYL-001	TAMP10030	Tampa lateral de caixa da integrada – porta
	NYL-042	NYLO00042	Botão tampa furo 3/8 NYL
	NYL-357	NYLO00357	Tampa dos perfis PU-047 / 048
	NYL-369	NYLO00369	Guia e limitador da veneziana
	NYL-370	NYLO0037	Guia da persiana de enrolar
	NYL-375	NYLO00375	Tampa da persiana
	NYL-411	NYLO00411	Tampa de topo do perfil SPI - 17
	NYL-601	TAMP10030	Tampa lateral da caixa integrada SPI - 98
	NYL-412	NYLO00412	Caixa de dreno e planos
	NYL-413	NYLO00413	Vedação superior 2 Planos
	NYL-442	NYLO00442	Batedeira para porta / janela
	NYL-444	NYLO00444	Guia de vedação e limitador da Folha
	PIV-752	PIVO00752	Pivo para bandeira projetante
	REC-011	RECD00011	Recolhedor com fita 20 mm
	ROL-464	ROLD00464	Roldana com regulagem com rolamento

ACESSÓRIO	CÓDIGO	CÓDIGO UNIVERSAL	DESCRIÇÃO
	ROL-465	ROLD00465	Roldana sem regulagem sem rolamento
	ROL-56	ROLD10020	Roldana FERMAX janela
	ROL-301	ROLD00301	Roldana nylon simples RN 2
	PCS-100	PLTC0396000	Palheta janela integrada branca A-39 CEGA
		PLTC0416000	
		PLTC0436000	
		PLTC0456000	
	PCS-015	PLTV0396000	Palheta janela integrada branca
		PLTV0416000	
		PLTV0436000	
		PLTV0456000	

ELEVAÇÃO VISTA EXTERNA

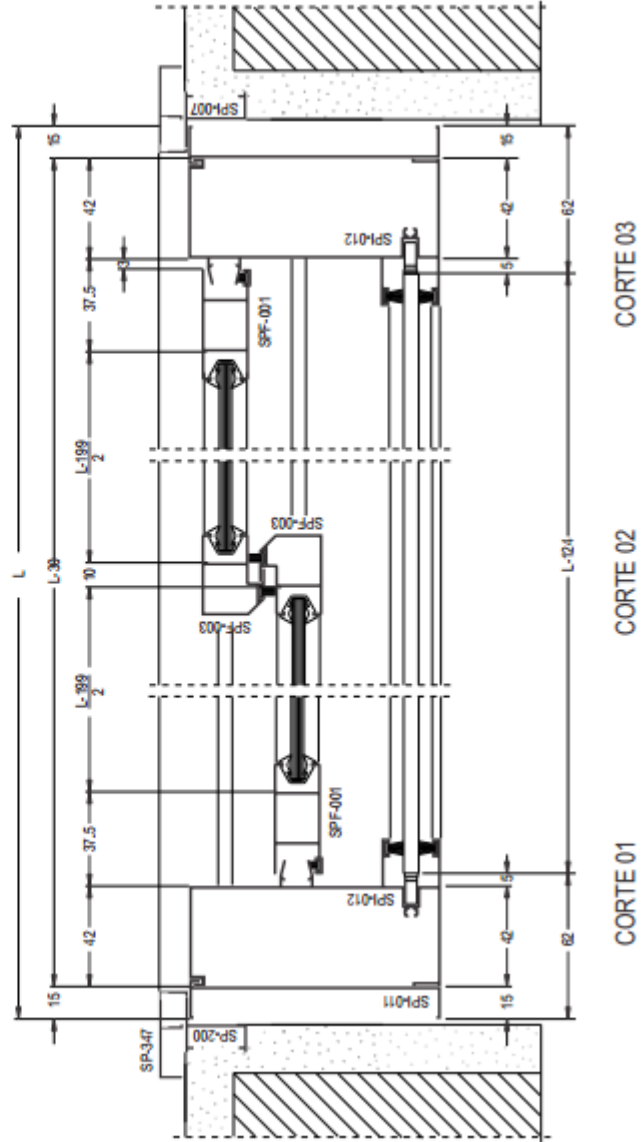
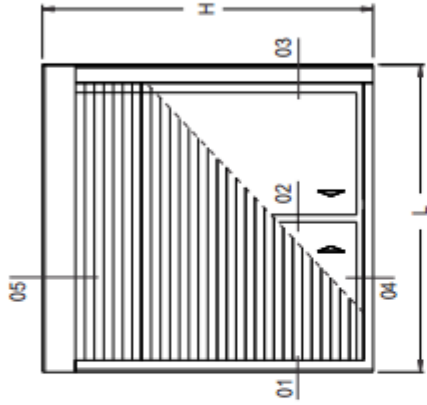

LADO EXTERNO

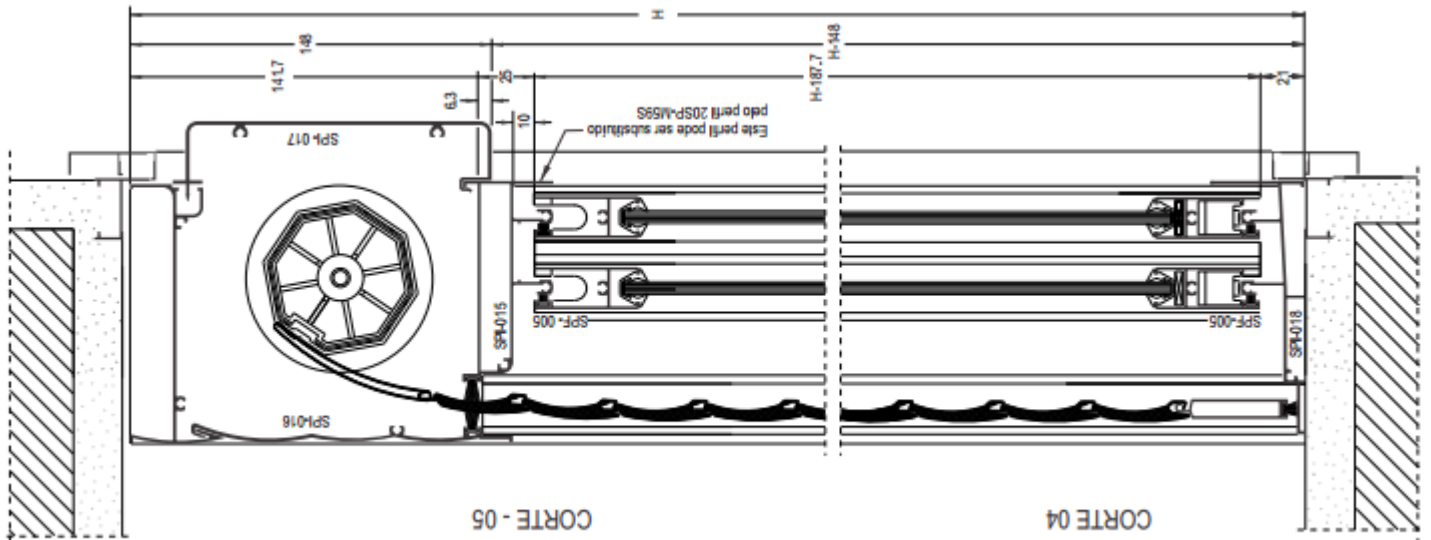

LADO EXTERNO

ELEVAÇÃO VISTA EXTERNA

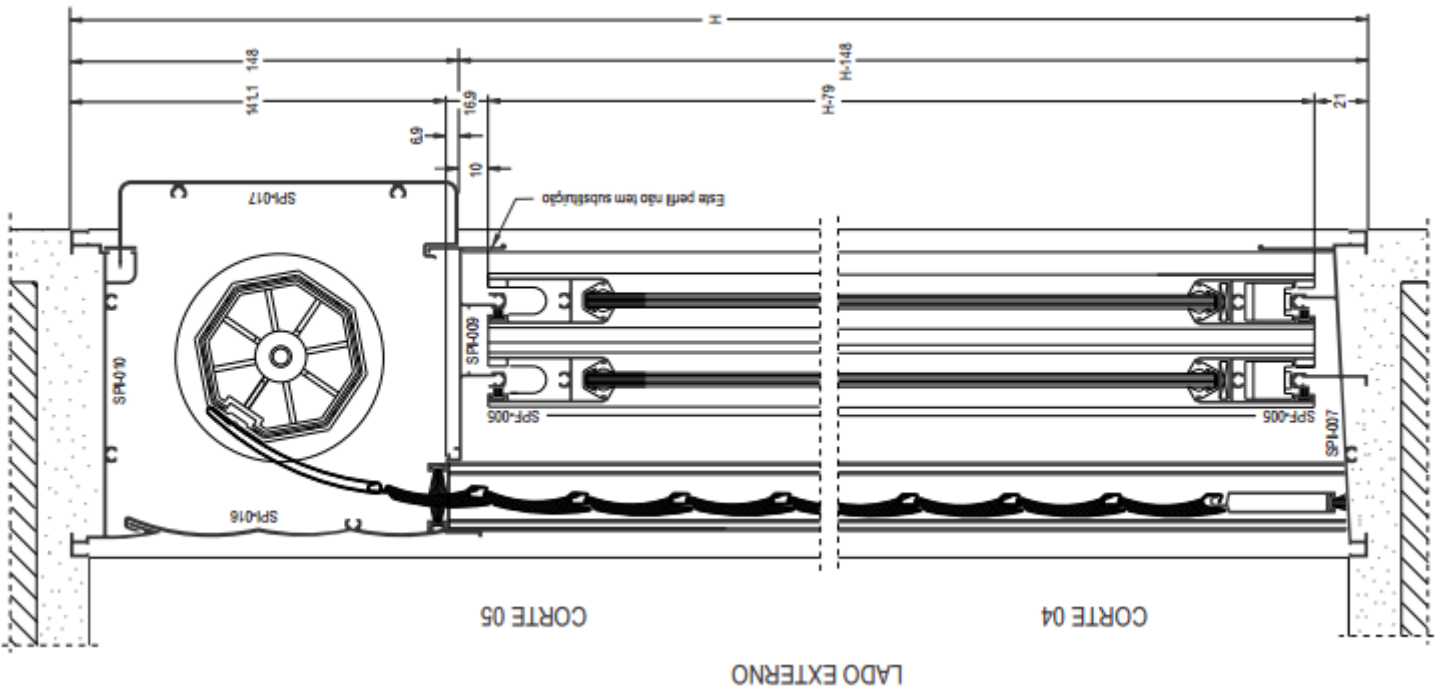
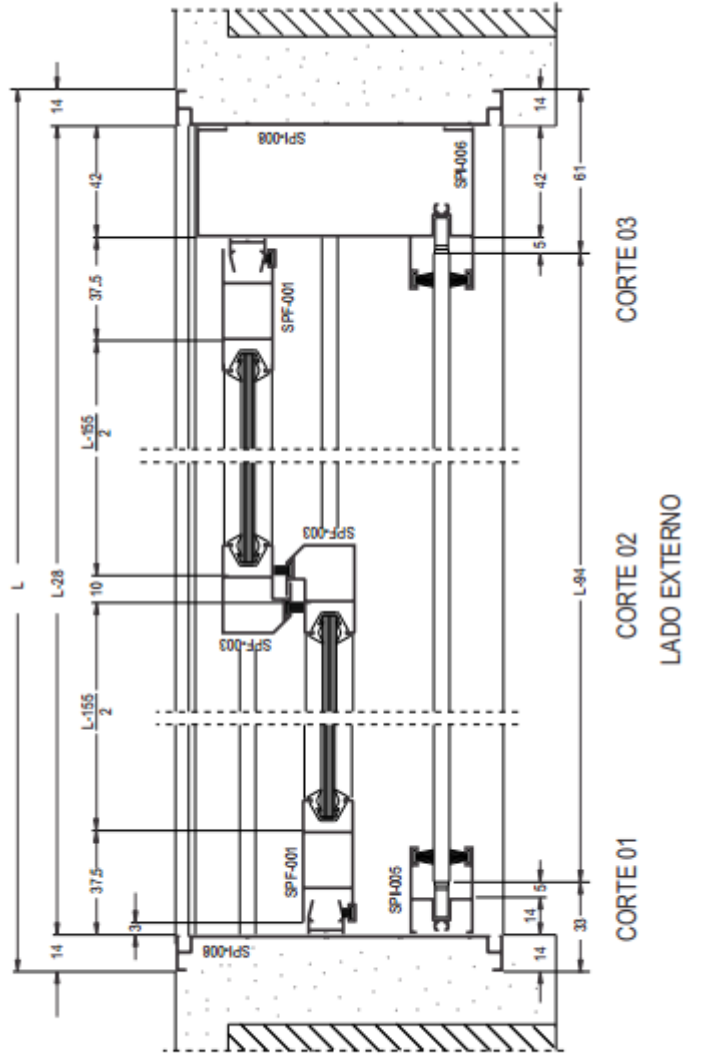
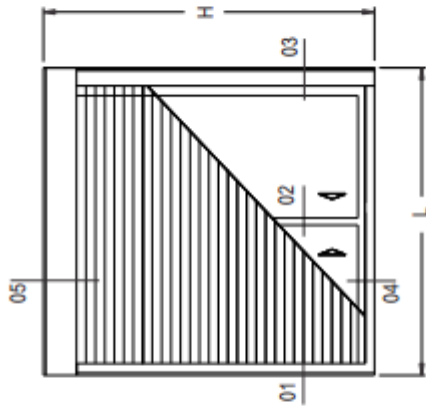

ELEVAÇÃO VISTA EXTERNA

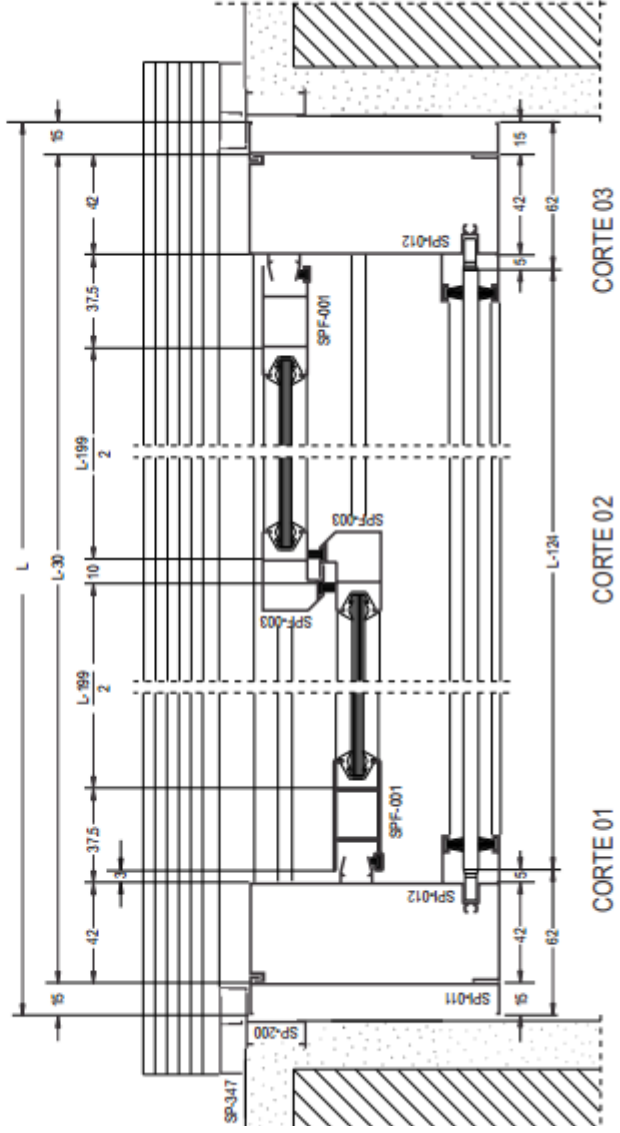
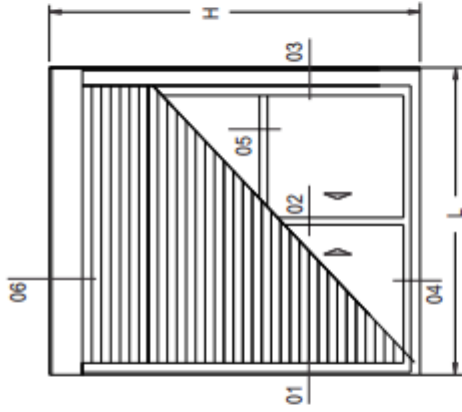

LADO EXTERNO

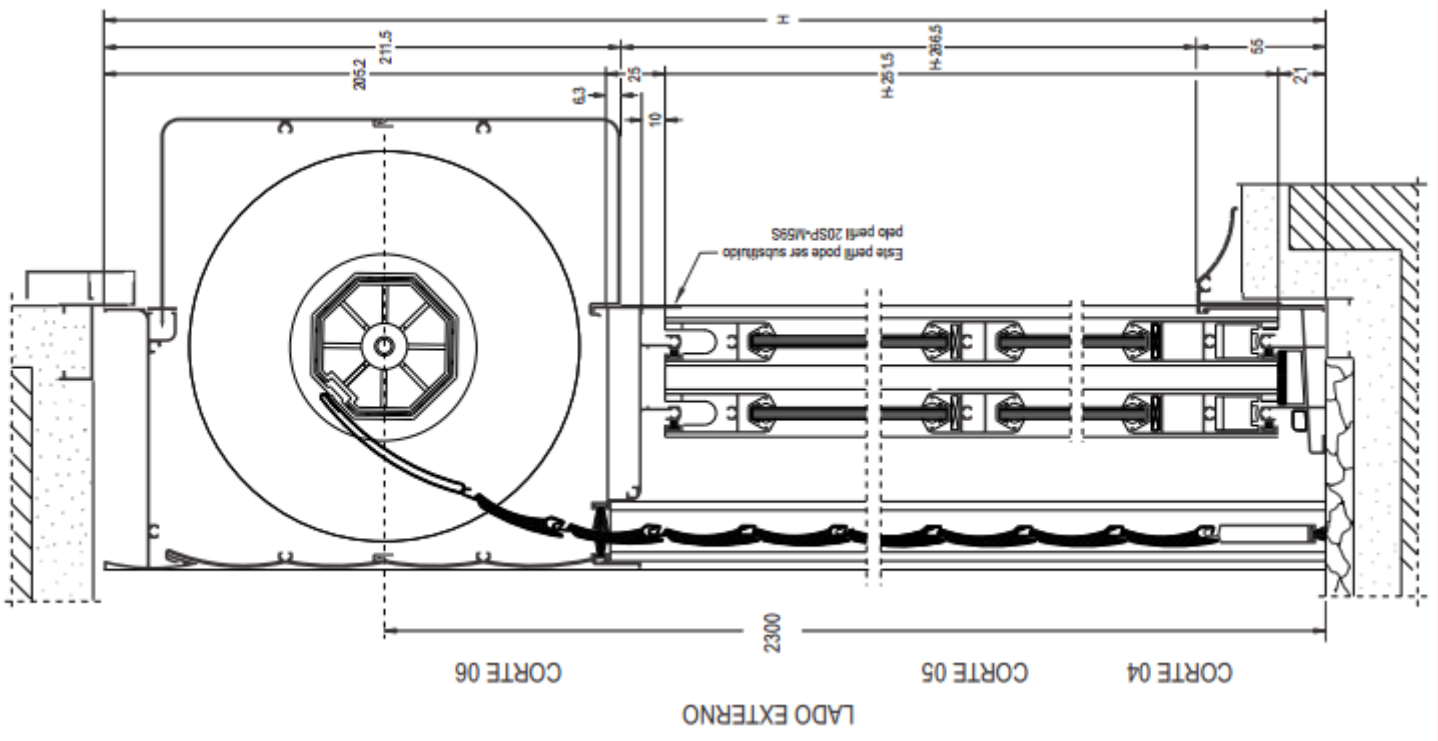

LADO EXTERNO

PROJETOS ORIENTATIVOS

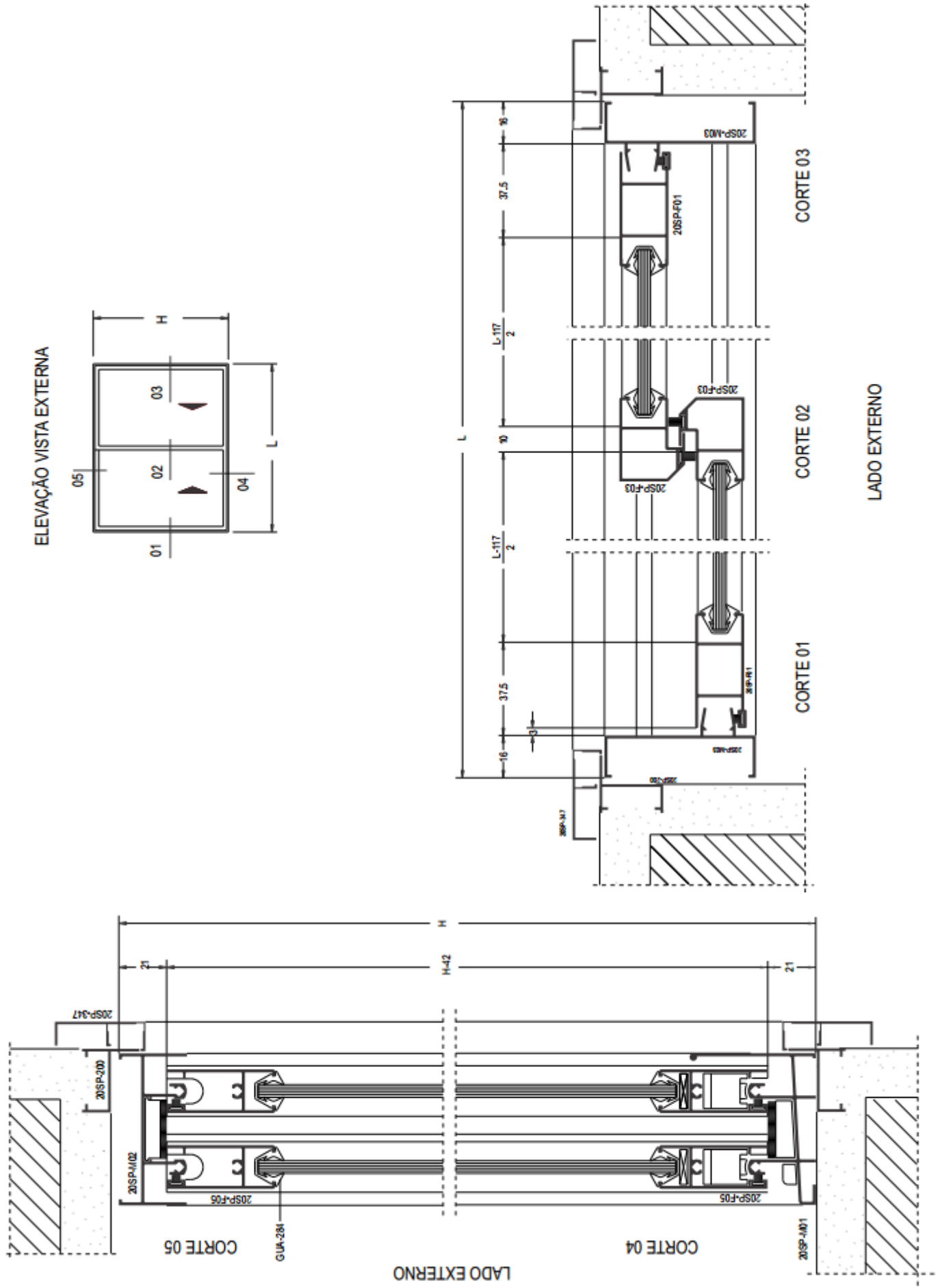

ELEVAÇÃO VISTA EXTERNA

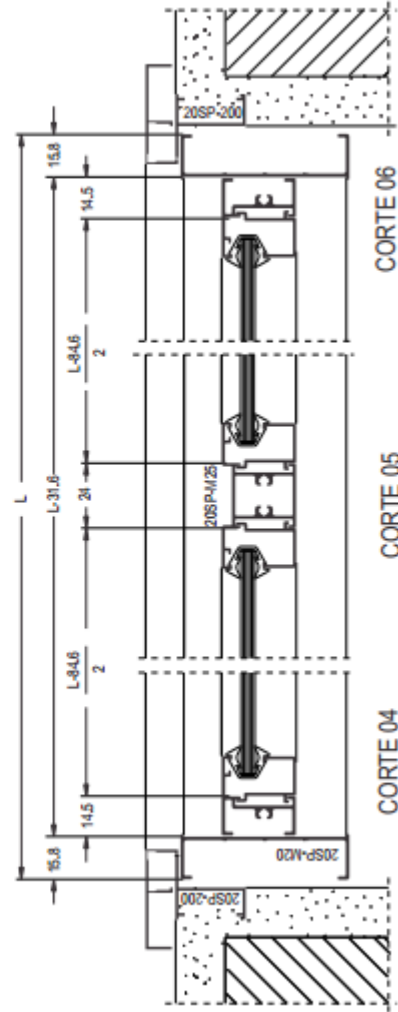
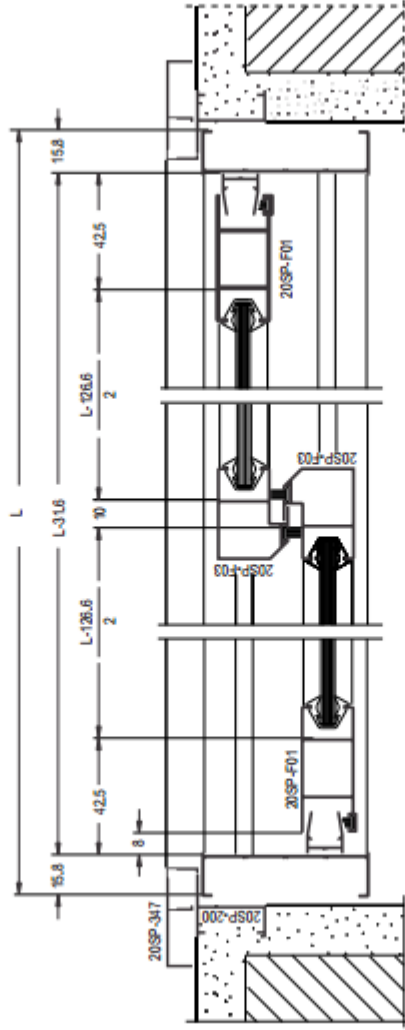

LADO EXTERNO

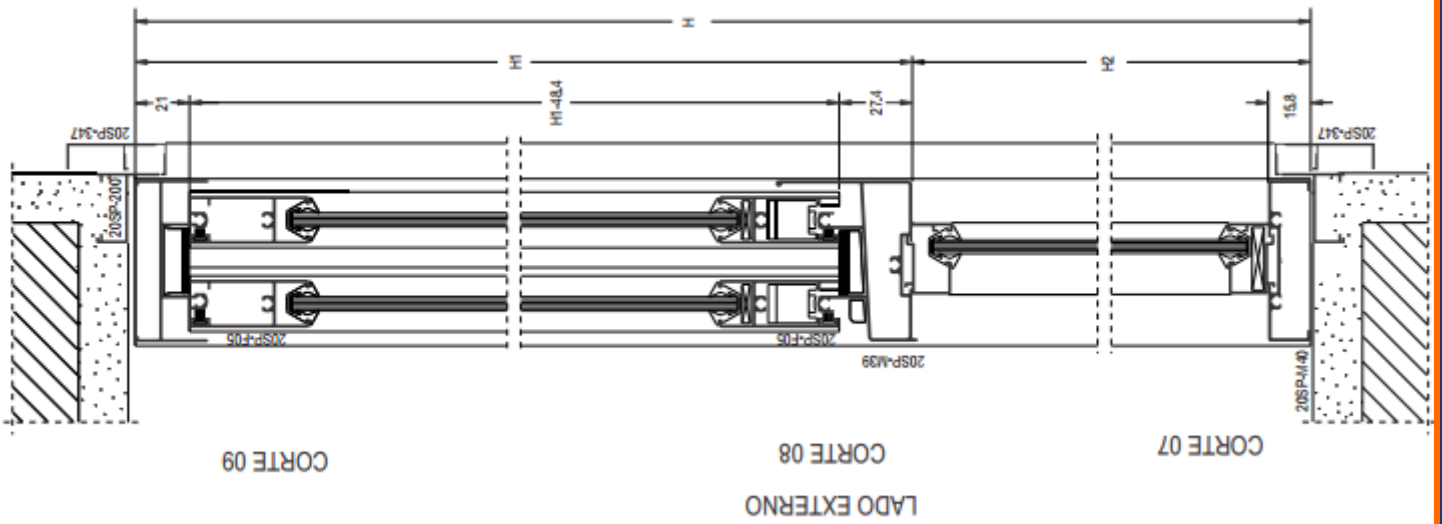

LADO EXTERNO

PROJETOS ORIENTATIVOS

ELEVAÇÃO VISTA EXTERNA

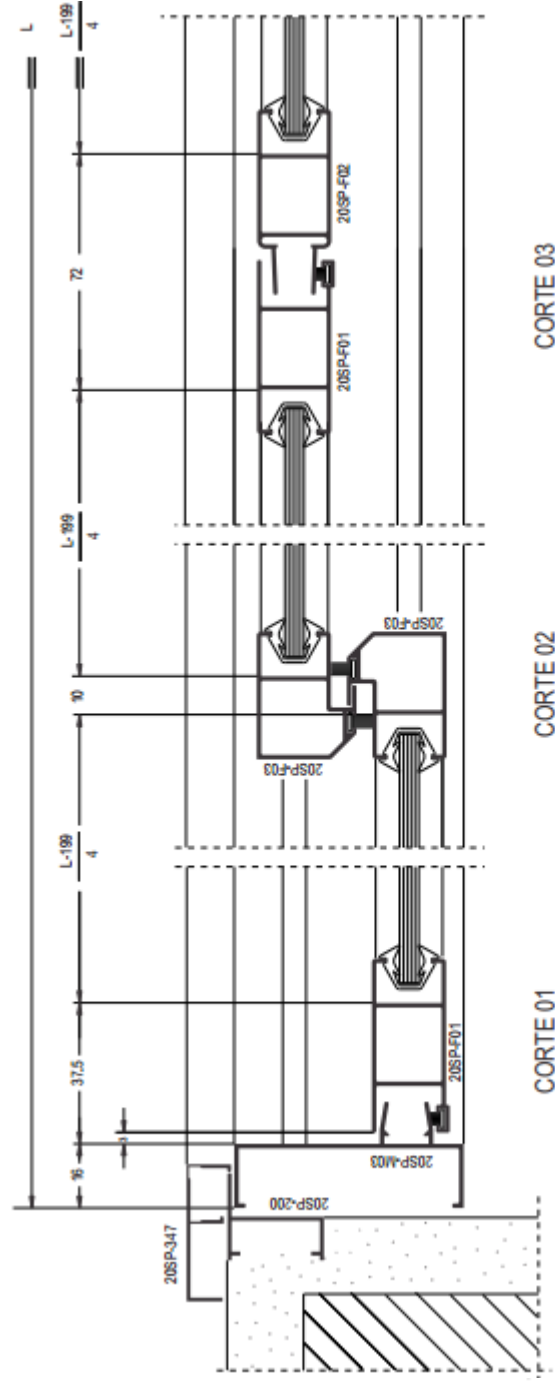
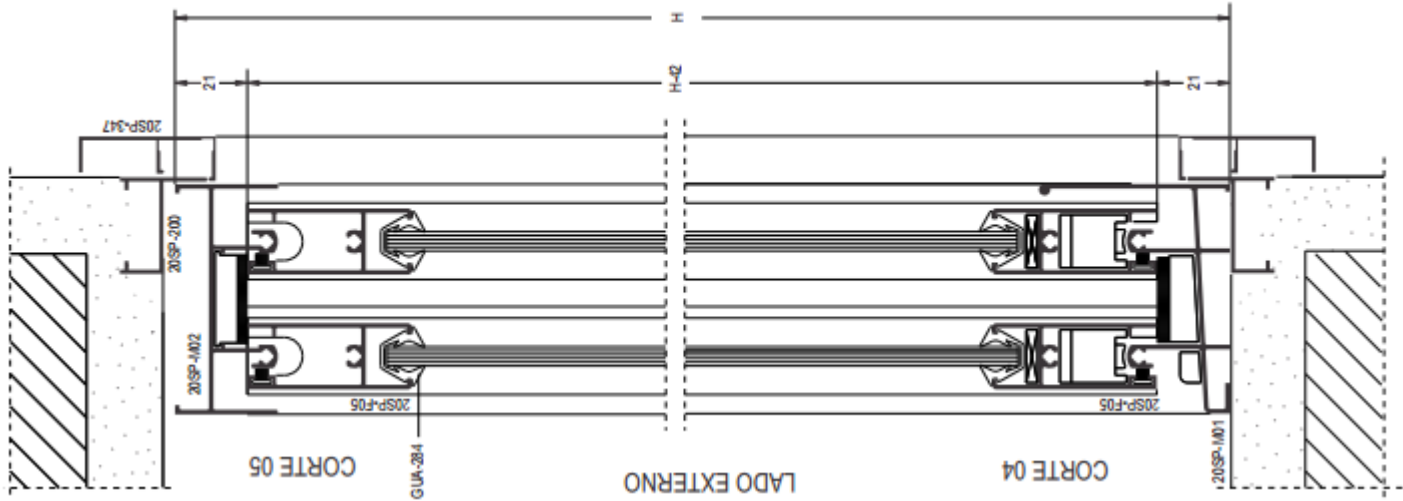
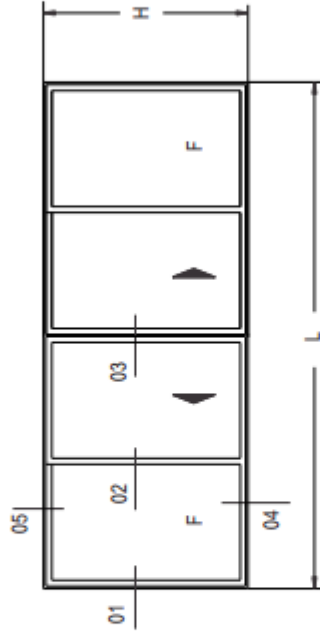

LADO EXTERNO

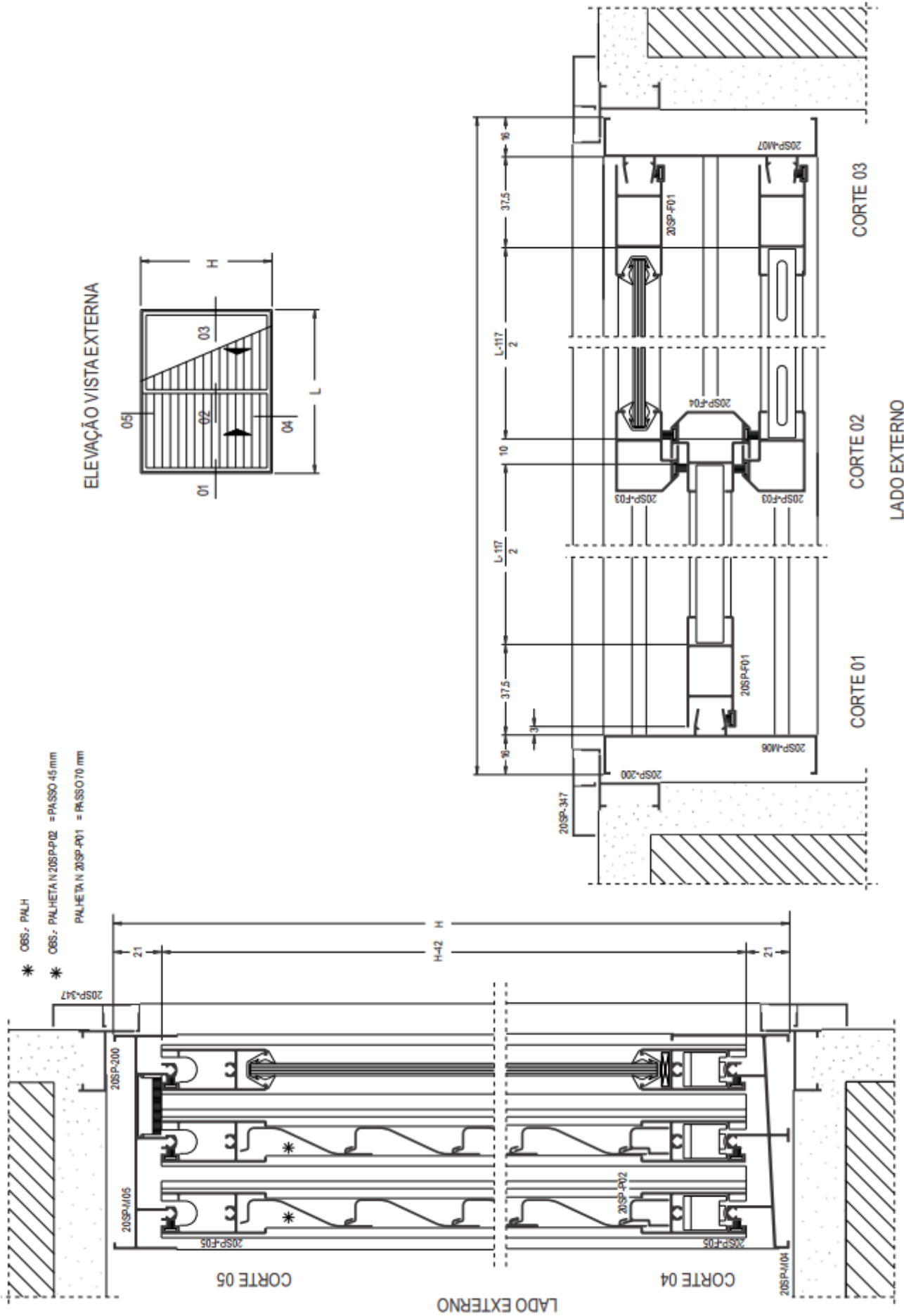

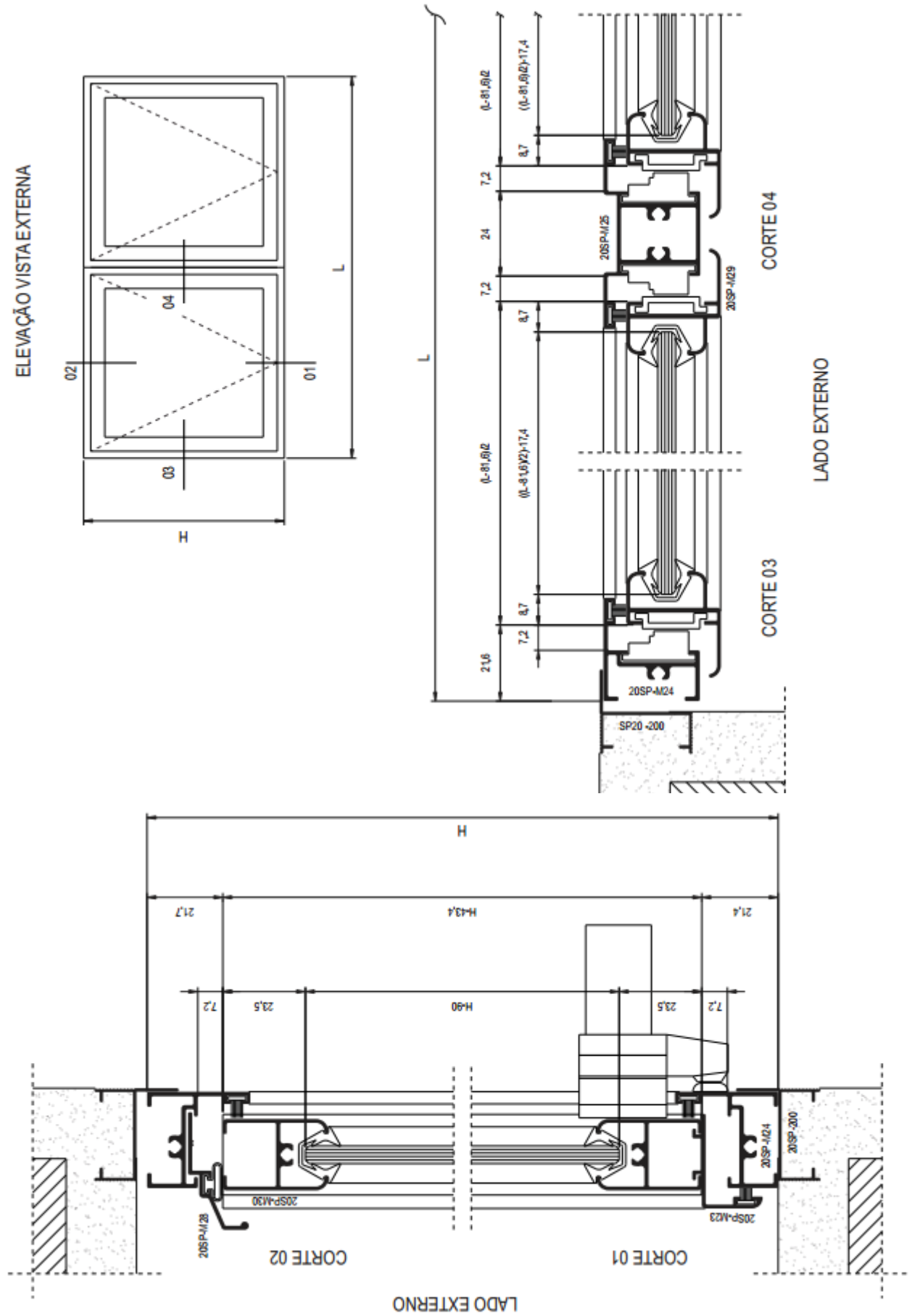

ELEVAÇÃO VISTA EXTERNA

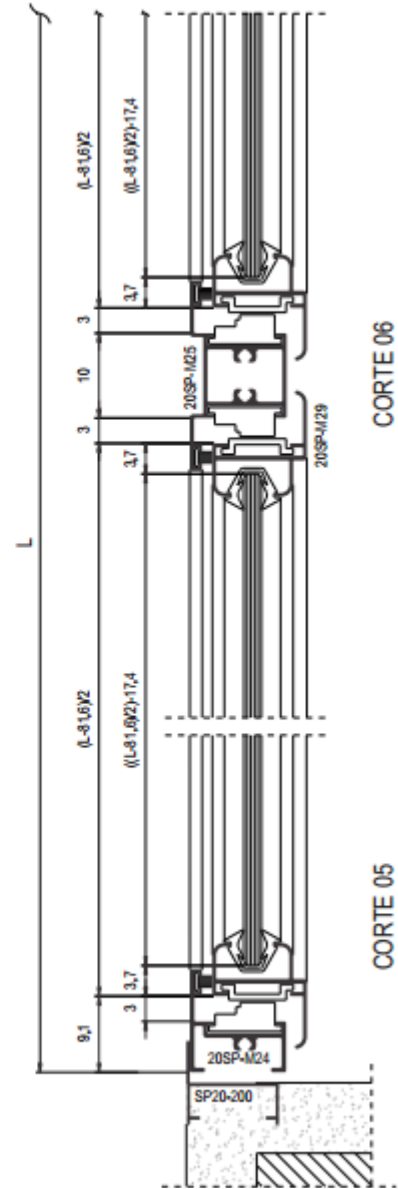
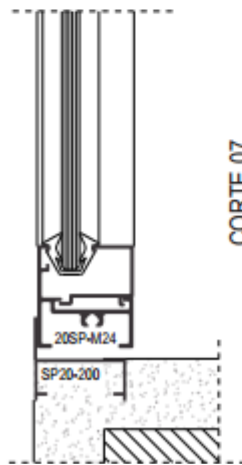
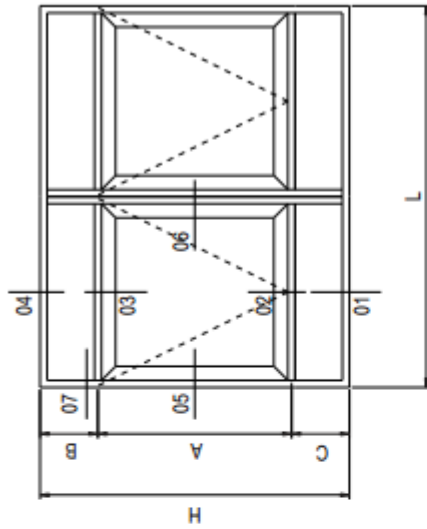

LADO EXTERNO

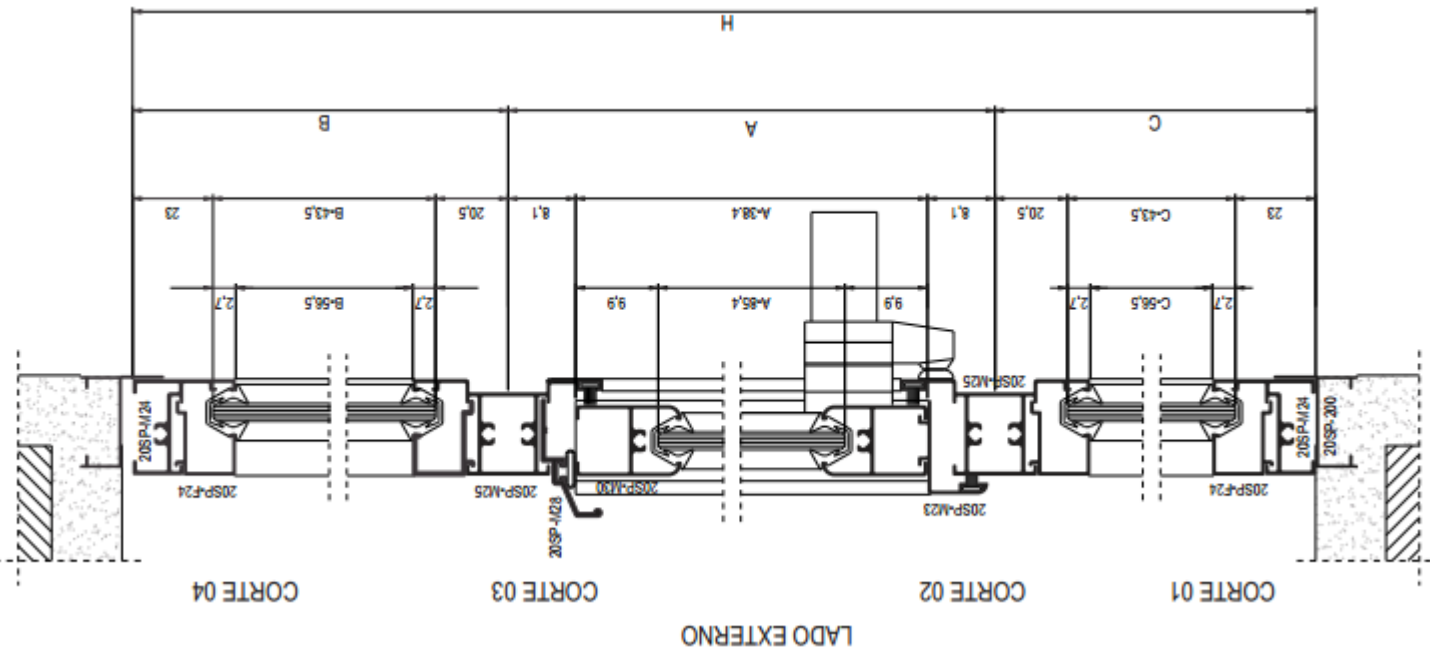

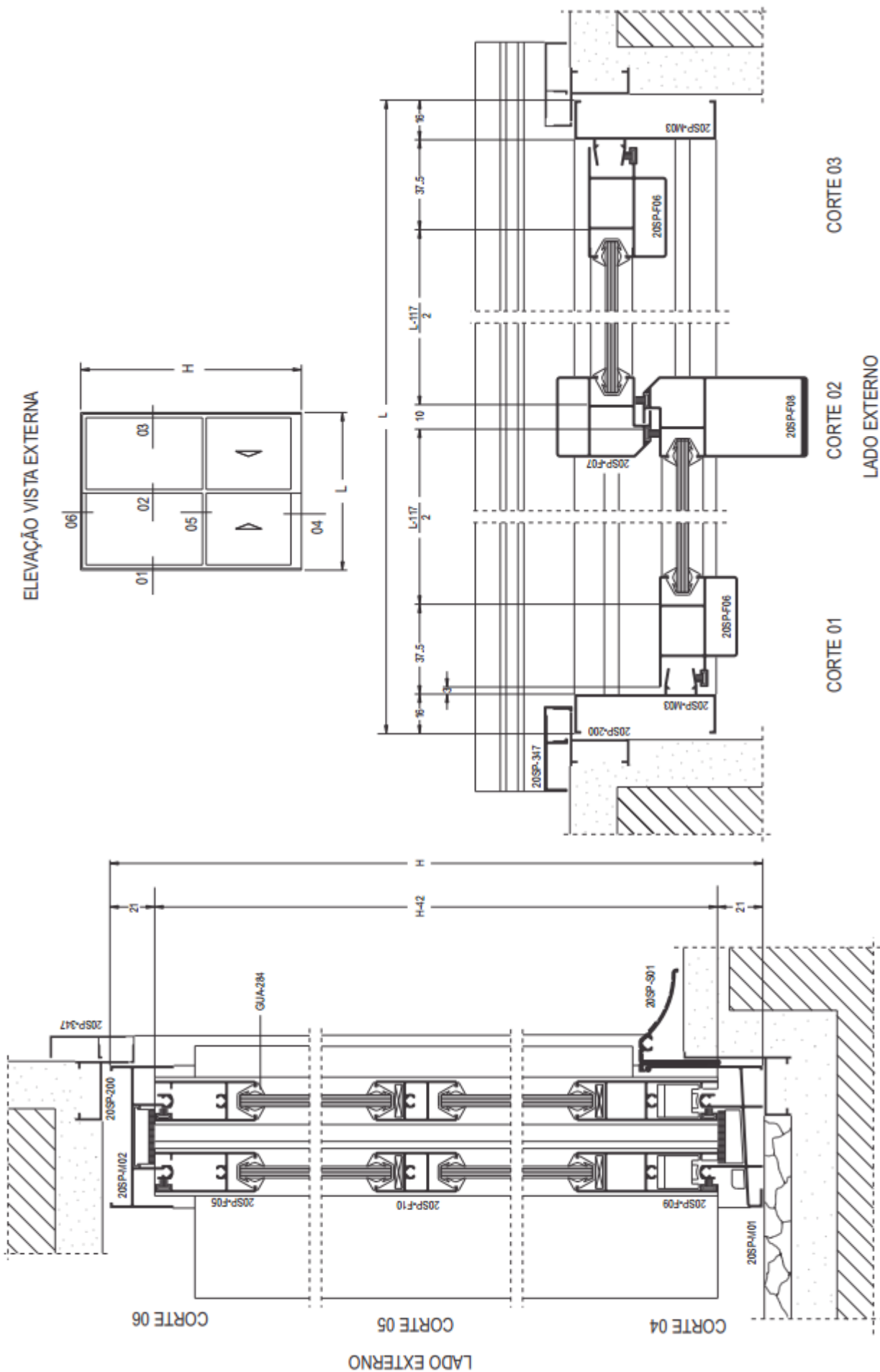

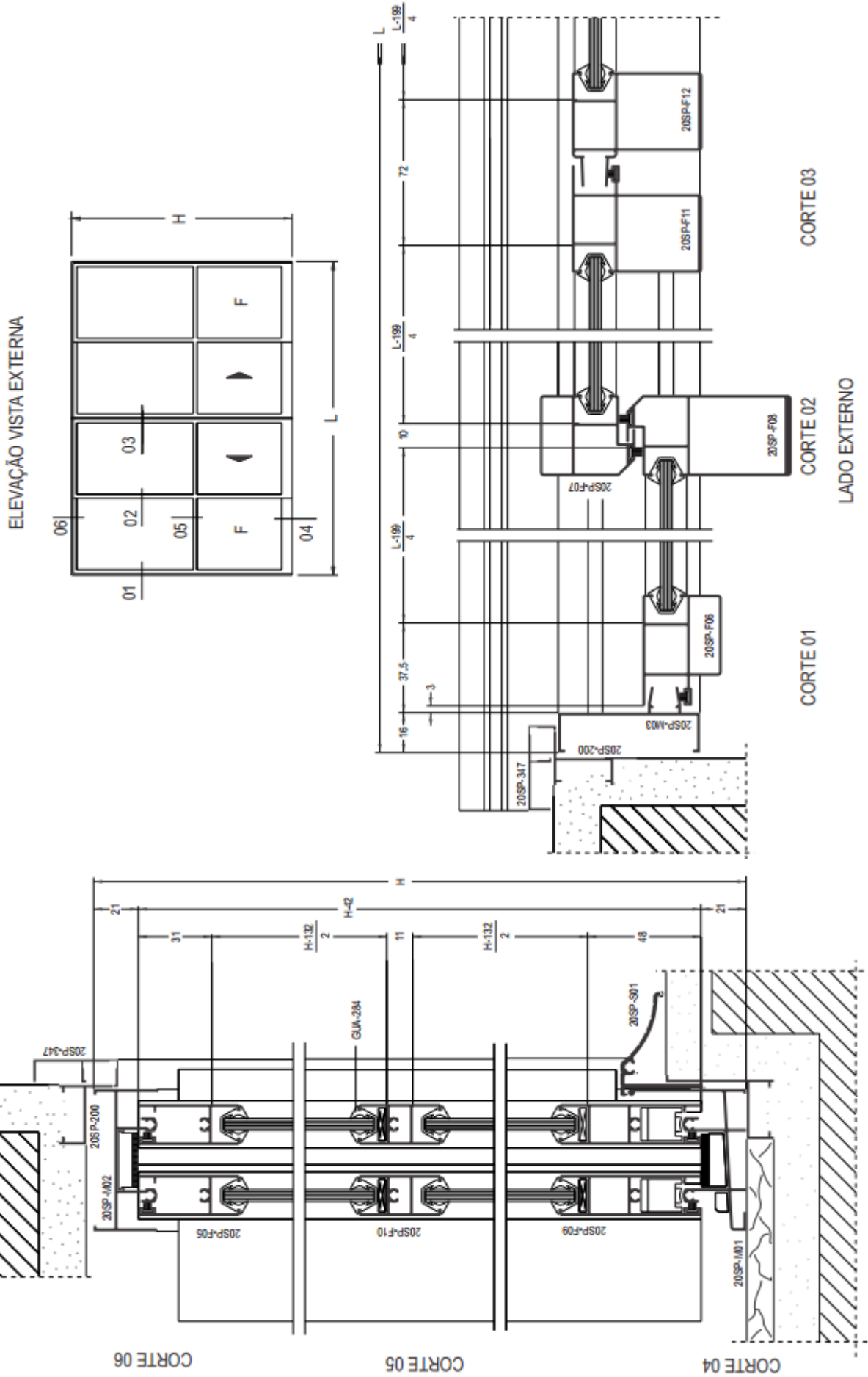

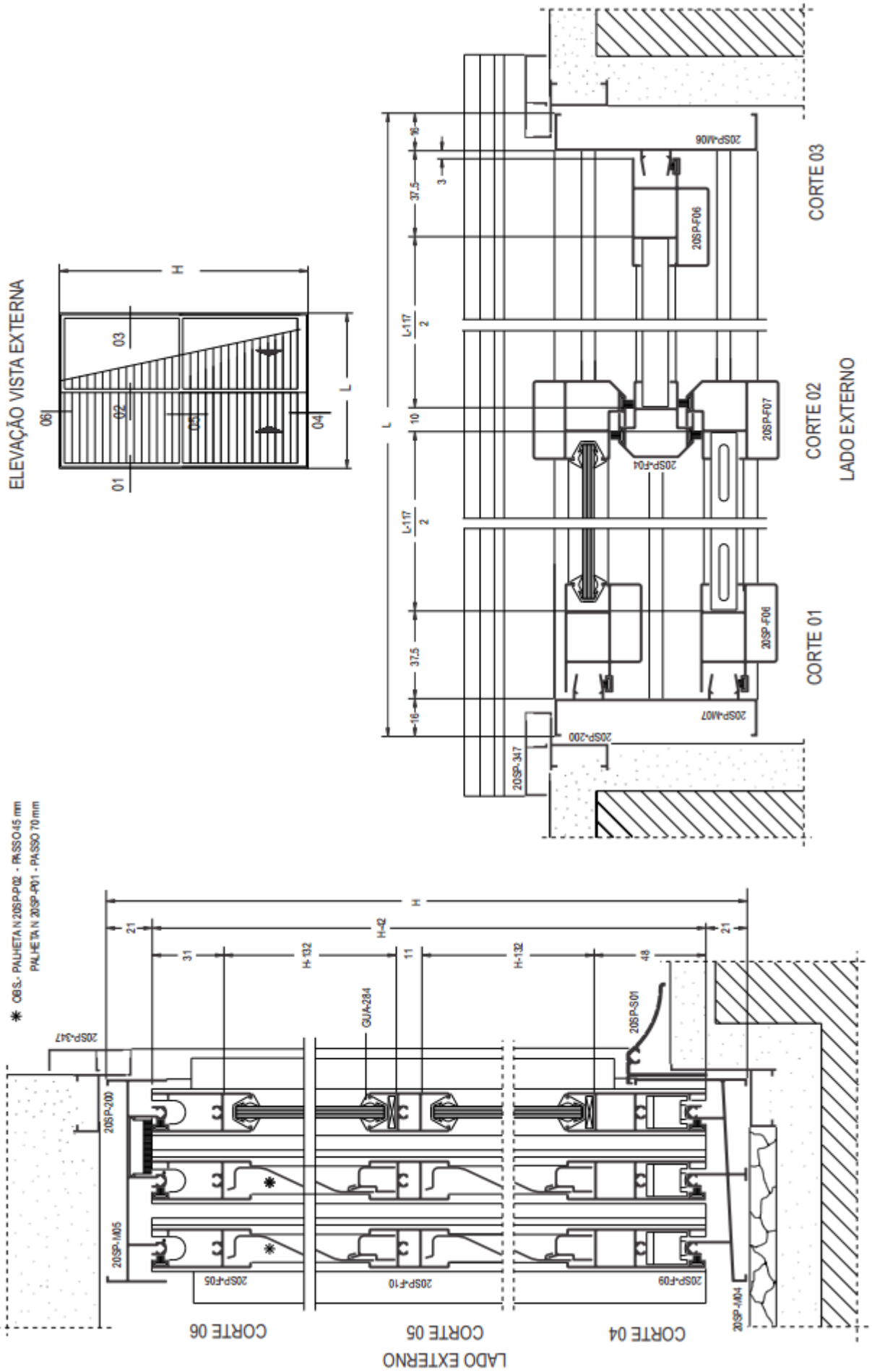

ELEVAÇÃO VISTA EXTERNA

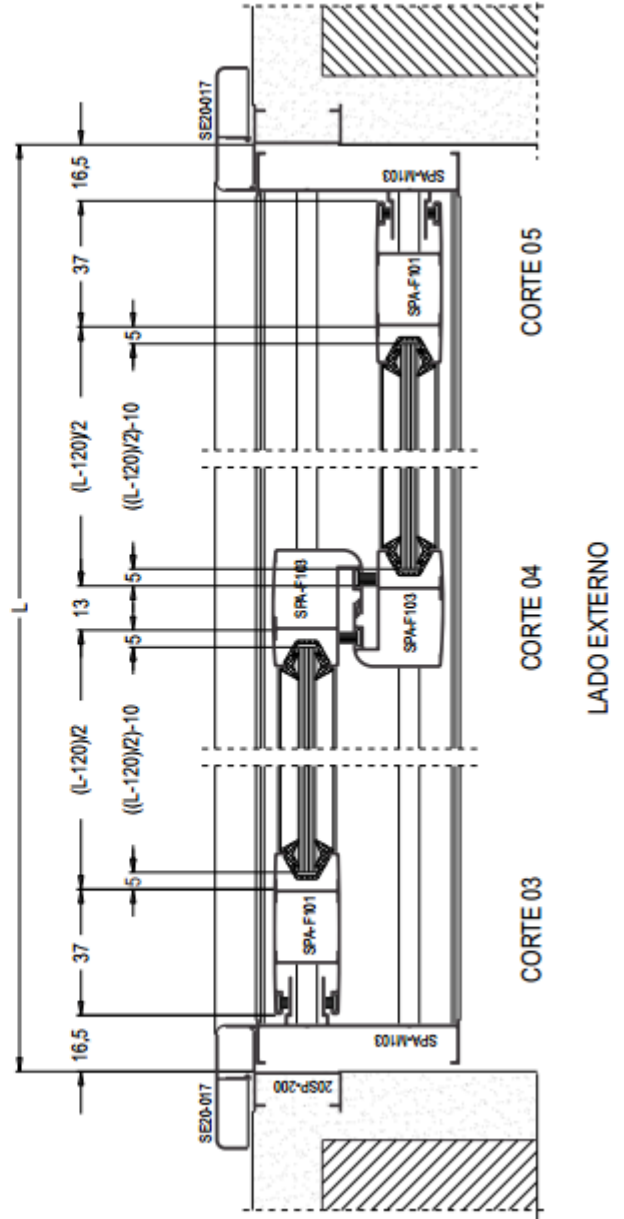
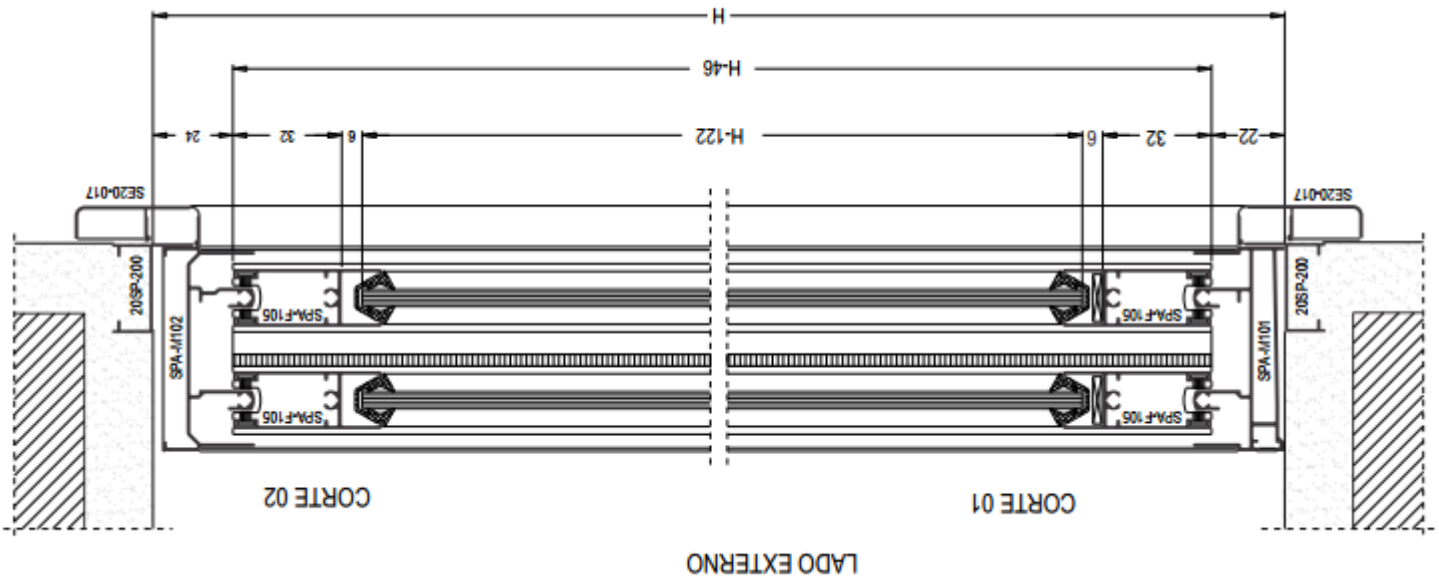
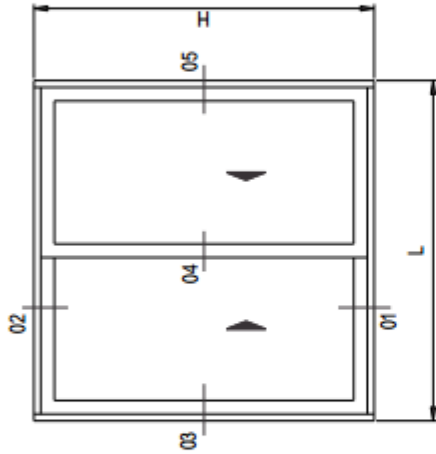

ELEVAÇÃO VISTA EXTERNA

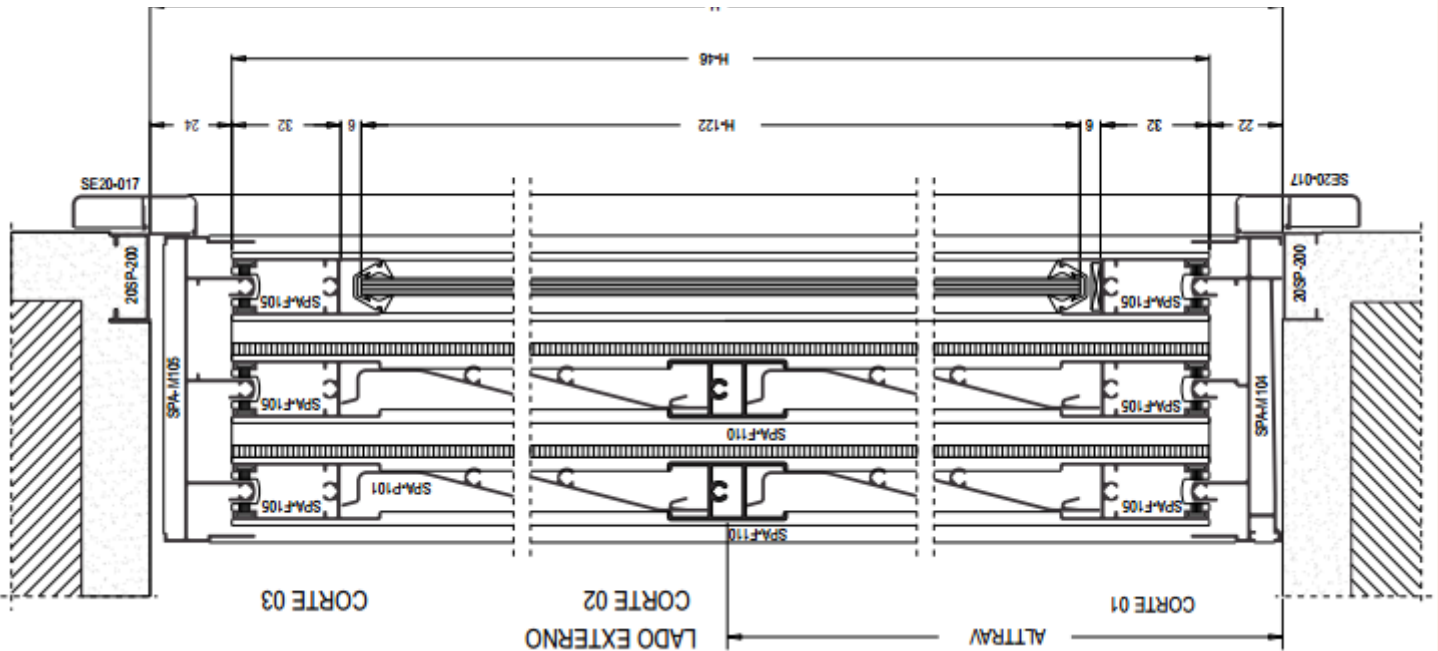
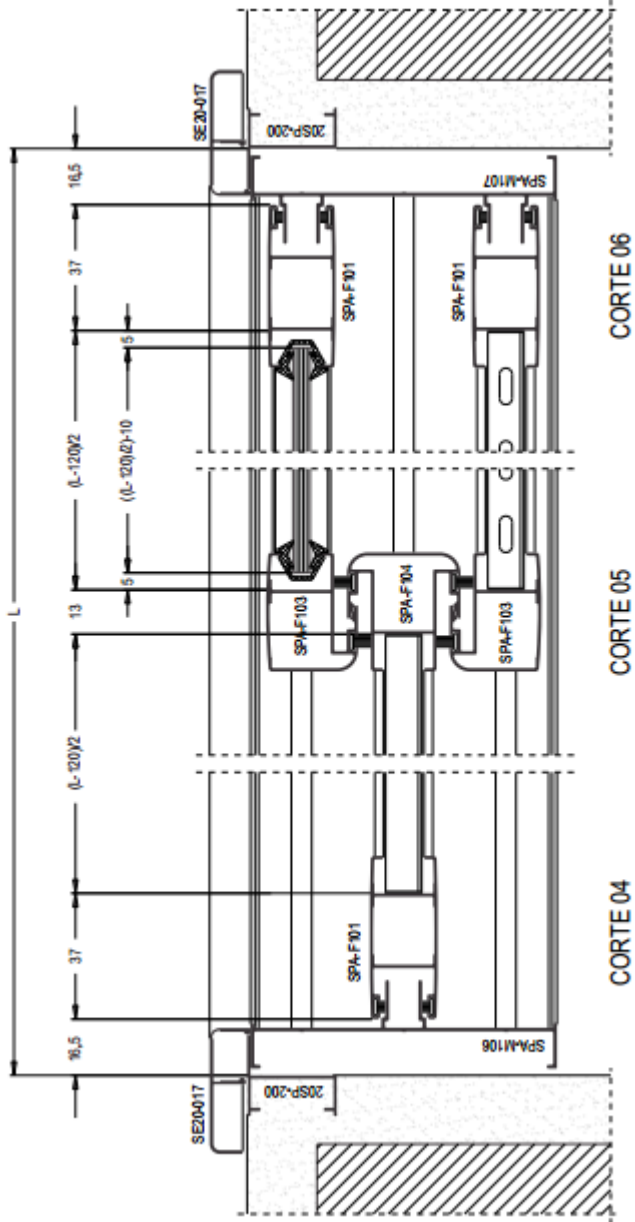
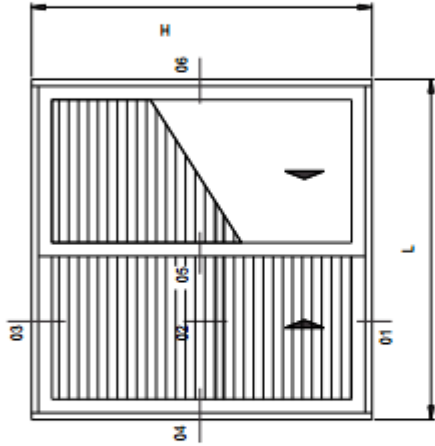

ELEVAÇÃO VISTA EXTERNA

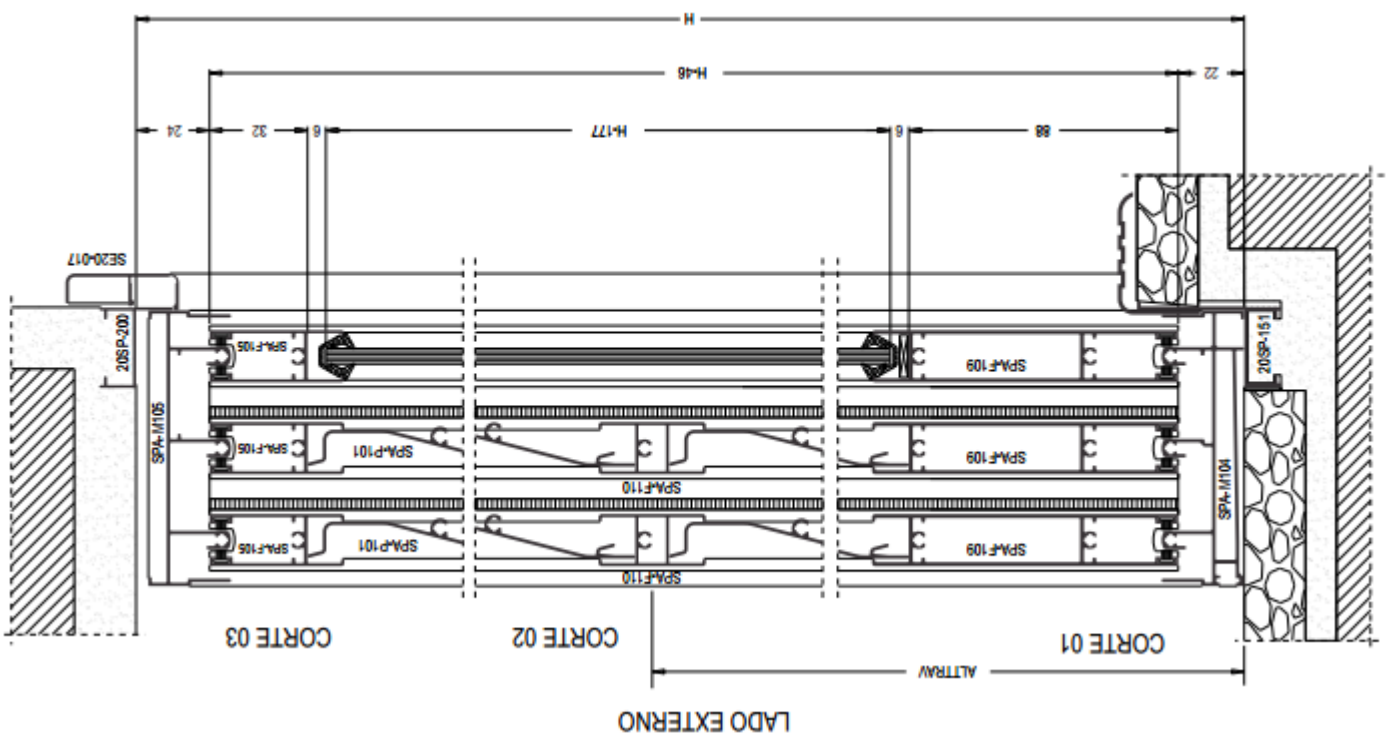
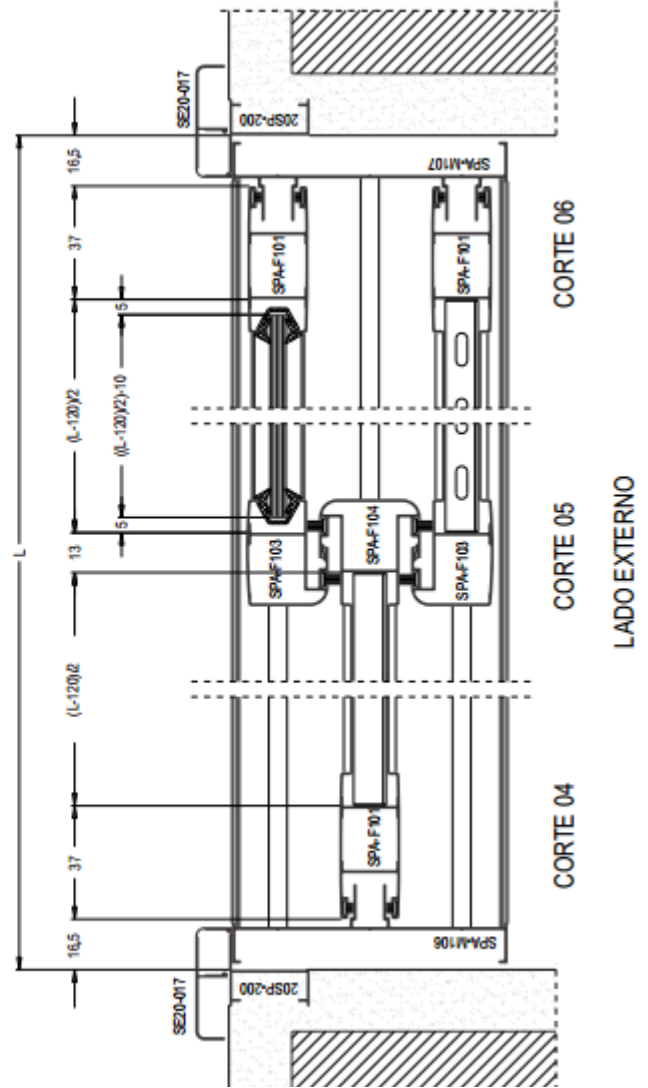
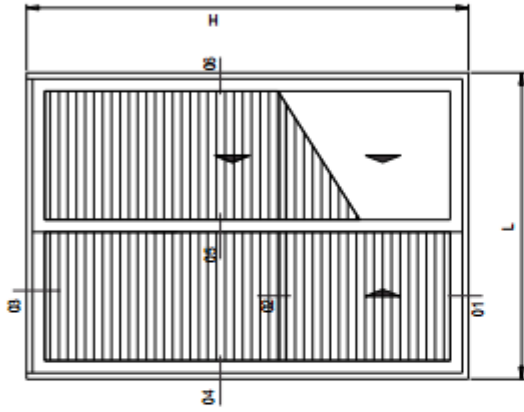

Isopletas dos ventos
(em metros por segundo)



Figura 1

Gráfico das isopletas da velocidade básica do vento: "V" em m/s no Brasil.

No Brasil, o comportamento de uma esquadria está regulamentada pela Norma NBR 10821.

Esta norma fixa as condições de desempenho de caixilhos em edificações residenciais e comerciais e visa assegurar ao consumidor, o recebimento de produtos com condições mínimas exigíveis de desempenho, especialmente quanto à resistência a cargas uniformemente distribuídas e que apresenta um roteiro de cálculo da pressão de ensaio (vento e vedação).

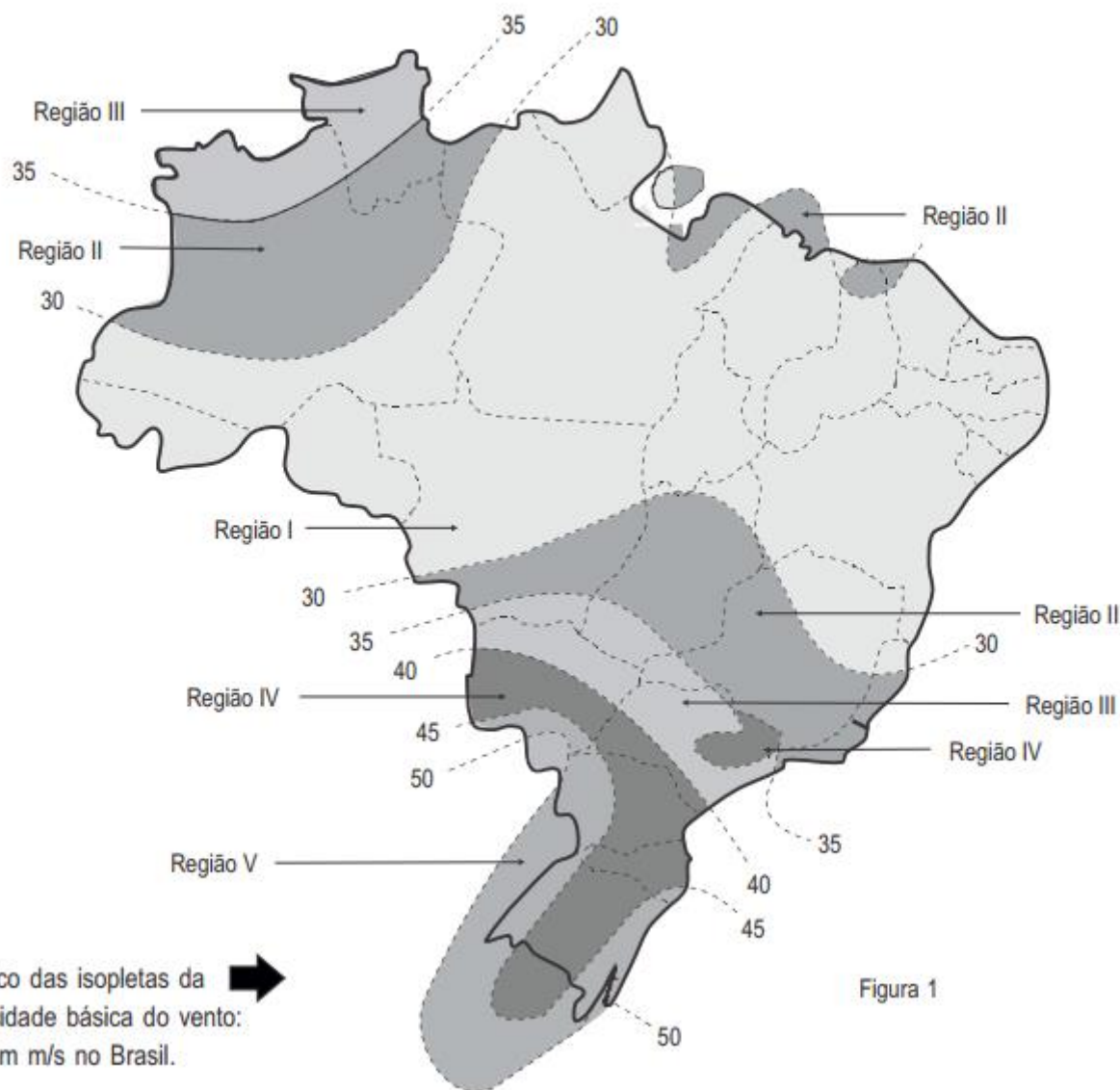
TABELA 1: Pressão de ensaio de cargas uniformemente distribuídas.

	Classe de utilização	Região do País	Pressão de projeto Pp em Pa	Pressão de sucção, Em Pa, P. x 0,8	Pressão de ensaio p=Pp x 1,5 em Pa
NORMAL	Residencial Unifamiliar ou Comercial simples até 2 pavimentos	I	300	350	450
		II	400	500	600
		III	550	650	800
		IV	650	800	950
		V	850	1000	1250
MELHORADA	Residencial ou Comercial até 4 pavimentos ou 12 metros	I	450	550	650
		II	600	700	900
		III	800	950	1200
		IV	1000	1200	1500
		V	1200	1450	1800
REFORÇADA	Comercial pesada ou edifícios residenciais com mais de 5 pavimentos	Todas as regiões	Calcular conforme NBR 6123	Calcular conforme NBR 6123	Calcular conforme NBR 6123
EXCEPCIONAL	Arquiteturas especiais (shopping, industriais, hospitais, etc...)	Todas as regiões	Calcular conforme NBR 6123	Calcular conforme NBR 6123	Calcular conforme NBR 6123

Notas:

- 1) Na classe reforçada, os valores de pressão, calculados conforme a NBR-6123, deverão ser, pelo menos, iguais aos valores das pressões de ensaio da classe Melhorada.
- 2) Nos casos de arquiteturas especiais de classe Excepcionais valores de pressão de ensaio, calculados conforme a NBR-6123, quando inferiores aos valores da classe Melhorada, deverão ser justificados através de ensaios em túneis de vento ou planilhas de cálculo e assinadas por um responsável técnico.

TABELA 2: Pressão de ensaio de estanqueidade à água

	Classe de utilização	Região do País	Pressão de estanqueidade à água – Pressão de projeto de vento – Pp x 0,15, em Pa
NORMAL	Residencial Unifamiliar ou Comercial simples até 2 pavimentos	I	300
		II	400
		III	550
		IV	650
		V	850
MELHORADA	Residencial ou Comercial até 4 pavimentos ou 12 metros	I	450
		II	600
		III	800
		IV	1000
		V	1200
REFORÇADA	Comercial pesada ou edifícios residenciais com mais de 5 pavimentos	Todas as regiões	Pressões de ensaio = o maior dos dois valores. 0,15 x Pp (pressão de projeto das cargas de vento) e os valores das pressões da classe Melhorada
EXCEPCIONAL	Arquiteturas especiais (shopping, industriais, hospitais, etc...)	Todas as regiões	Pressões de ensaio = o maior dos dois valores. 0,15 x Pp (pressão de projeto das cargas de vento) e os valores das pressões da classe Melhorada

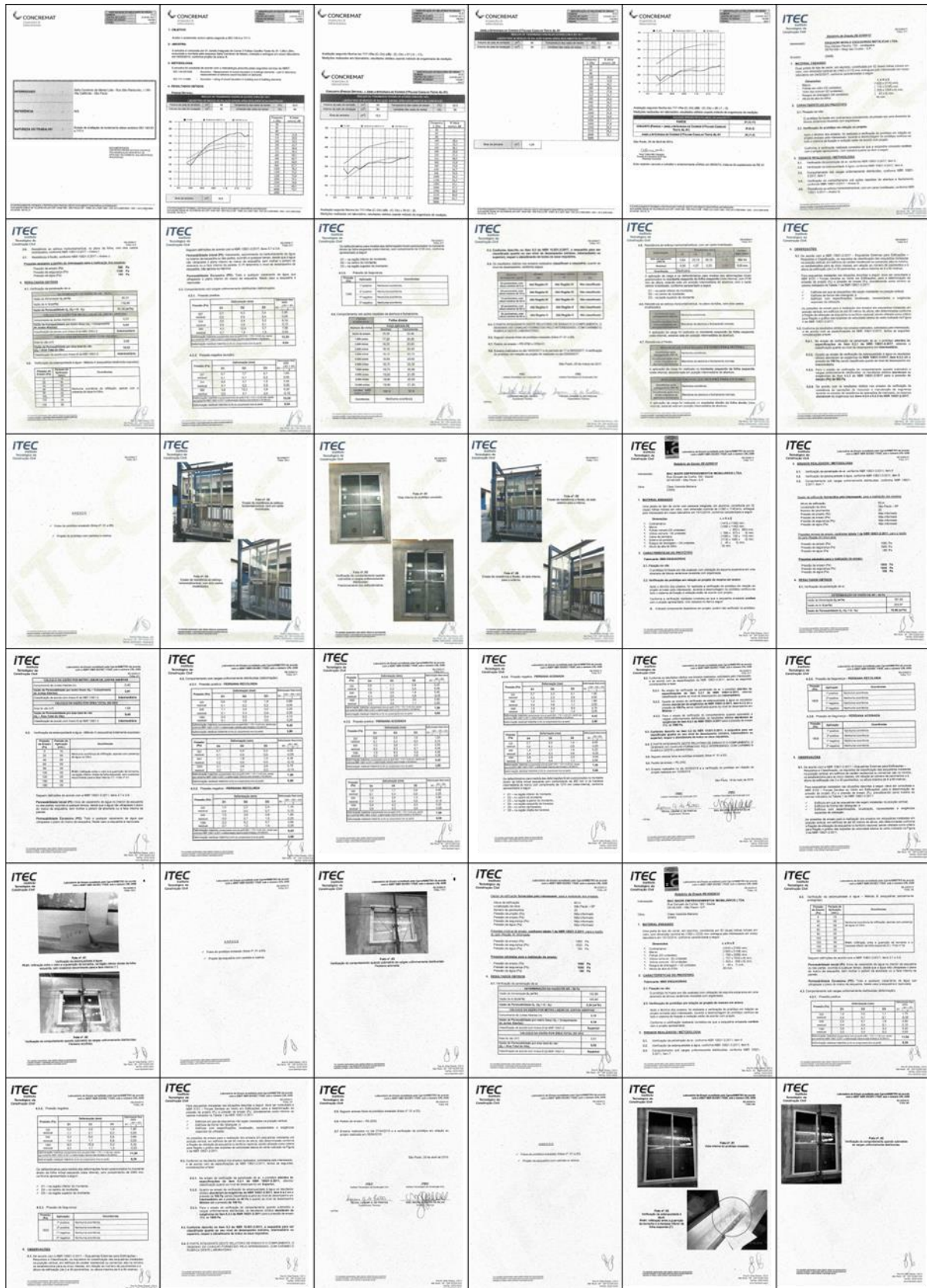

PARA ACESSAR AOS TESTES DA LINHA EM TAMANHO MAIOR,
CONTATE NOSSO DEPARTAMENTO TÉCNICO OU UM DE NOSSOS
VENDEDORES.

aluminorte Desde 1986
alumínio e acessórios

